



# CITY COMMISSION WORKSHOP MEETING AGENDA

Thursday, November 14, 2024 at 5:00 PM

City Commission Chambers – 105 S. 2ND Street, Flagler Beach, FL 32136

---

**ALL MEETING ITEMS WILL BE CONTINUED UNTIL MEETING IS COMPLETE.**

- 1. Call the meeting to order**
- 2. Pledge of Allegiance followed by a moment of silence to honor our Veterans, members of the Armed Forces and First Responders**
- 3. General Business**
  - a.** Discussion regarding Veranda Bay Master Plan Development Agreement.
- 4. Commission Comments**
- 5. Adjournment**

**RECORD REQUIRED TO APPEAL:** In accordance with Florida Statute 286.0105 if you should decide to appeal any decision the Commission makes about any matter at this meeting, you will need a record of the proceedings. You are responsible for providing this record. You may hire a court reporter to make a verbatim transcript. The City is not responsible for any mechanical failure of the recording equipment. In accordance with the Americans with Disabilities Act, persons needing assistance to participate in any of these proceedings should contact the City Clerk at (386) 517-2000 ext 233 at least 72 hours prior to the meeting. The City Commission reserves the right to request that all written material be on file with the City Clerk when the agenda item is submitted.

1 Michael D. Chiumento III, Esq.  
2 Chiumento Law, PLLC.  
3 145 City Place, Suite 301  
4 Palm Coast, FL 32164  
5  
6

7 ----- [SPACE ABOVE THIS LINE FOR RECORDING DATA] -----

8  
9 **VERANDA BAY**  
10 **AMENDED AND RESTATED**  
11 **MASTER PLANNED DEVELOPMENT AGREEMENT**  
12  
13

14  
15 **THIS AMENDED AND RESTATED MASTER PLANNED DEVELOPMENT**  
16 **AGREEMENT**, (this “Development Agreement”) is made and executed this \_\_\_\_ day of  
17 \_\_\_\_\_, 2024 by and between the CITY OF FLAGLER BEACH, a Florida  
18 municipal corporation (the “City”), with an address at 105 S. Second St., Flagler Beach,  
19 Florida, 32136, and the master developer of the Subject Property, PALM COAST  
20 INTRACOASTAL, LLC, a Florida limited liability company with an address at 3129  
21 Springbank Lane, Suite 201, Charlotte, NC 28226 (The “Declarant”).  
22

23 **RECITALS.**

24  
25 A. In 2005, Flagler County adopted Ordinance 2005 -22 recorded at O.R. Book 1429,  
26 Page 19, Public Records of Flagler County, Florida which rezoned and approved the  
27 negotiated PUD Development Agreement (the “2005 Development Agreement”) for a  
28 mixed-use development affecting approximately 1,999 acres of land.

29 B. As negotiated in the 2005 Development Agreement, the owner conveyed  
30 approximately 1,100 acres of land designated as environmental lands to Flagler County  
31 for the purpose of public services, preservation, conservation, and public recreation for

1 the benefit of citizens of Flagler County. In addition, the owner conveyed to the County  
2 two parcels of land for a public boat ramp and for public safety. These lands conveyed  
3 to the County are collectively called the “Public Land”.

4 C. As negotiated in the 2005 Development Agreement, the remaining +/- 899 acres of  
5 land (the “PUD Property”) is permitted to be developed as a mixed-use development  
6 and was annexed into the City of Flagler Beach, Flagler County, Florida, on the  
7 Effective Date of this Agreement (**Exhibit “A”**).

8 D. The Declarant also owns two parcels of a land, totaling +/- 54.8 acres, which are  
9 located directly adjacent to the PUD Property (**Exhibit “A”**) within the City (the  
10 “Declarant Parcel”) and which have a land use designation of residential uses.

11 E. The Declarant desires to amend the presently approved development plan for the  
12 PUD Property and the Declarant Property (collectively, the “Subject Property; **Exhibit**  
13 **“A”**) by creating a single integrated mixed-use community providing for a marina and  
14 other amenities.

15 F. Subsequent to the effective date of the 2005 Development Agreement, the  
16 Declarant properly developed and conveyed a portion of the PUD Property (the  
17 “Approved Properties”; **Exhibit “B”**) to third parties for uses including but not limited  
18 to single-family residential lots.

19 G. The Declarant has the sole authority to amend the terms and conditions of the 2005  
20 Development Agreement as permitted by law.

21 H. The City’s Comprehensive Plan shows the Subject Property, *infra*, designated as  
22 Residential and Commercial on its Future Land Use Map.

23

1 I. Based upon the finding of facts and conclusions of law, the City Commission  
2 determines that this Development Agreement is consistent with the City's  
3 Comprehensive Plan, the City's Land Development Regulations (2024) (the "LDR"),  
4 and that the conditions, terms, restrictions, and requirements set forth herein are  
5 necessary for the protection of the public health, safety, and welfare of the citizens of  
6 the City.

7 J. The City Commission further finds that this Development Agreement is consistent  
8 with an exercise of the City's powers under the *Municipal Home Rule Powers Act*,  
9 Article VIII, Section 2(b) of the *Constitution of the State of Florida*, Chapter 166,  
10 *Florida Statutes*, the *City Charter*, other controlling laws, and the City's police powers.

11 K. This is a non-statutory Development Agreement which is not subject to or enacted  
12 pursuant to the provisions of Sections 163.3220 -163.3243, *Florida Statutes*.

13 L. The Parties, therefore, desire to amend and restate the 2005 Development  
14 Agreement affecting the Subject Property.

15 **NOW, THEREFORE**, it is hereby resolved and agreed by and between the City and the  
16 Declarant that the Declarant's rezoning application for a Master Planned Development is  
17 approved subject to the Development Agreement's following terms and conditions:

18 **SECTION 1. RECITALS.**

19 The above recitals are taken as true, incorporated herein by this reference and form a  
20 material part of this Development Agreement upon which the City and the Declarant have  
21 relied.

1 **SECTION 2. REPRESENTATIONS OF DECLARANT.**

2  
3 The Declarant hereby represents and warrants to the City that the Declarant is an owner  
4 or authorized agent of the Subject Property in accordance with the title opinion or title  
5 certification provided by the Declarant to the City issued by an attorney or title insurance  
6 company licensed to provide services in the State of Florida, with said title opinion or  
7 certification showing all liens, mortgages, and other encumbrances not satisfied or released of  
8 record relative to the Subject Property.

9 **SECTION 3. THE PROJECT & MPD MASTER PLAN.**

10  
11 (a) The Declarant shall continue to develop the Subject Property as a mixed-use  
12 development generally consistent with the MPD Master Plan (**Exhibit “C”**) hereinafter  
13 referred to as the “Project”.

14 (b) This Project is a mixed-use, low-density development focused on providing  
15 significant Open Space, including preserved lands. The Project provides for low density  
16 residential development, commercial development along State Road 100 (“SR100”) and a  
17 marina village. The residential uses shall include multiple types of housing opportunities such  
18 as low density residential development, medium density multi-family uses, and high density  
19 multi-family uses; none exceeding thirty five feet (35’) in height. Property designated as  
20 Commercial, generally located adjacent to SR100, is intended to provide shopping, office and  
21 other commerce and economic development opportunities for the Project’s residents and the  
22 general public. However, this area may also be developed into a mixed-use center where  
23 residential uses are integrated with the general commercial uses to further the concept of  
24 “work, shop and play”. The commercial area identified adjacent to the Intracoastal Waterway  
25 (“ICW”) is intended to be developed into a commercial or private marina which may include

1 a ship store, restaurants, retail uses or other commercial uses integrated with medium density  
 2 to high density residential uses. The Project will preserve a minimum of forty percent (40%)  
 3 of the Project (+/- 300 acres) as Open Space, which includes, but is not limited to, preserved  
 4 lands subject to passive recreation, buffers and wetlands. Recognizing that approximately  
 5 1,100 acres of land were previously dedicated to the County for (i) preservation, (ii) access to  
 6 the ICW, and (iii) public safety, the Parties agree that the Project benefits the entire Flagler  
 7 County community, including the residents of the City of Flagler Beach. The Project's density  
 8 and intensity are provided below.

9

Project	899 ac.
Residential units (max.)	2735 units (3.2 units/ac)
Commercial density	480,000 sq ft
Open Space (40%)	>300 ac.

10

11 (c) The MPD Master Plan is conceptual in nature and subject to change as  
 12 permitted by this Development Agreement. The locations of improvements are graphical in  
 13 nature and will be located as the Project is designed, permitted and approved by the City. For  
 14 example, the location of sidewalks, stormwater ponds, and other improvements noted on the  
 15 MPD Master Plan are not required to be constructed in the exact locations as shown. The  
 16 Parties agree that all such improvements will be engineered and located on each tract, or  
 17 portion thereof, as developed and subsequently approved by the City.

1 **SECTION 4. APPROVAL OF MPD DEVELOPMENT AGREEMENT, MPD MASTER PLAN**

Formatted: Font: Bold, Underline

2 **APPROVAL, AND DEVELOPMENT REVIEW PROCESS.**

3 \_\_\_\_\_ The City Commission, at its regular meeting on \_\_\_\_\_, 2024

Formatted: Font: 12 pt

4 and pursuant to Ordinance 2024-\_\_, adopted this Development Agreement affecting the  
5 Subject Property.

Formatted: Normal, No bullets or numbering

6 (a) The MPD Master Plan generally depicts the layout of the Project and delineates  
7 the approximate property boundaries, Spine Road (as defined below), Project entrances,  
8 general location of Tracts and intended uses, all of which may be further refined in the future  
9 at the discretion of the Declarant. Moreover, the MPD Master Plan satisfies the requirements  
10 of the City’s Comprehensive Plan, the LDR and other City regulations, including but not  
11 limited to City Ordinance 2024-06.

12 (b) The MPD Master Plan contains a level of detail satisfactory to permit the  
13 Project or portions of it to proceed directly to Preliminary Plat and/or Site Plan approval of any  
14 portion of the Subject Property which shall be approved by the City.

15 (c) This Development Agreement (i) does not affect the entitlements, rights or  
16 responsibilities of any owner of the Approved Properties and (ii) affirms any and all vested  
17 rights of the Approved Properties as provided in the 2005 Development Agreement and the  
18 Approvals as defined by City of Flagler Beach Ordinance 2024-\_\_ (the “Pre-Annexation  
19 Agreement”).

20 (d) The development of the Project has commenced, satisfies all timing or phasing  
21 requirements by the City’s Comprehensive Plan and LDR, and is therefore deemed to be  
22 ongoing. Absent written notice from the Declarant to the City abandoning the Project or  
23 terminating this Agreement, this Agreement shall not expire or lapse. Notwithstanding, in the event

Formatted: Indent: Left: 0", Line spacing: Double

1 development activities cease for a period of ten (10) years, this Agreement shall expire unless otherwise  
2 agreed to by the parties.

Deleted: ¶  
¶

3 (e) The Parties agree and acknowledge that, in the event, the Declarant obtains title to any  
4 portion of those Public Lands (13-12-31-2850-0PL30-0000; 13-12-31-2850-0FD20-0010 and 13-12-  
5 31-2850-0PL20-0000) previously dedicated to the County, the Parties shall in good faith annex such  
6 into the City, amend its land use designation and rezone the property in a manner that is consistent  
7 with adjacent lands owned by the Declarant or its assigns.

Formatted: Body Text, Justified, Indent: First line: 0.5", Right: 0", Space Before: 0 pt, No bullets or numbering, Tab stops: Not at 1.08"

Deleted: e

Formatted: Font: Not Bold

8 **SECTION 5. MODIFICATIONS TO THE DEVELOPMENT AGREEMENT & MPD**

9 **MASTER PLAN.**

Formatted: Font: 12 pt

10 Modifications to the exact location of Tracts, roadways, primary sidewalk/pathway  
11 systems, and other improvements generally depicted on the MPD Master Plan are anticipated  
12 to change ("Minor Modifications") and shall be approved by the City Manager or its designee  
13 (the "Land Use Administrator" or "LUA") during review of construction documents, site plans,  
14 or Preliminary Plat for the Project or portions thereof, as long as the development standards  
15 contained in this Development Agreement are maintained. Moreover, the Land Use  
16 Administrator shall approve a Minor Modification in writing, without City Commission  
17 approval, for modifications to the Development Agreement, MPD Master Plan and any  
18 construction documents and Preliminary Plat for the Subject Property, provided that: (1) the  
19 maximum building height and maximum number of residential units permitted are not  
20 exceeded; (2) the Project setbacks from adjacent properties, Bulow Creek or buffers along  
21 John Anderson Highway are not modified; or (3) the approved plans maintain the general  
22 development standards in this Development Agreement. The Declarant may challenge the  
23 LUA's denial of a Minor Modification and, in writing, request a hearing before the City



1 Commission which will, in good faith, decide whether the change is deemed a Minor  
2 Modification. Only proposed changes that affect criteria (1) thru (3) above shall require City  
3 Commission approval or be deemed to require a rezoning, as provided by *Florida Statutes*,  
4 Chapter 163, or the City’s regulations. Otherwise, a Minor Modification or other change shall  
5 be deemed to be de minimis and shall be approved by the LUA as provided above.

6 **SECTION 6. PERMITTED USES.**  
7

8 The Declarant agrees to fully comply with the following uses and restrictions on the  
9 Subject Property. The Declarant must develop the Project generally consistent with the MPD  
10 Master Plan with the following approved uses on each Tract (**Exhibit “D”**), as provided by the  
11 table below. The design standards for the permitted use on each Tract shall comply with design  
12 standards provided in Section 12.1, Lot Dimensional Standards, below:

Formatted: Indent Left: 0"

<u>TRACT</u>	<u>ZONING DISTRICT</u>	<u>APPROVED USES</u>
A	Residential	SFR, Town House and Conservation
B	Residential	SFR, Town House, Multi-family
C	Residential	SFR, Town House, Multi-family
D	Residential	SFR, Town House, Multi-family
E	Commercial	Mixed-Use, Commercial, Town House, Multi-family, Marina
F	Residential	SFR, Town House, Multi-family
G	Residential	SFR, Town House, Multi-family
H	Residential	SFR, Town House, Multi-family
I	Commercial	Mixed-Use, Commercial, Town House, Multi-family
J1 & J2	Commercial	Mixed-Use, Commercial, Town House, Multi-family
K	Residential	SFR, Town House, Multi-family
L	Residential	SFR
M	Residential	SFR

13  
14  
15  
16

(a) **SFR:** The purpose of the Single-Family Residential (SFR) uses is to provide areas for detached single-family dwellings and accessory use, including ancillary dwelling

1 units permitted by State statutes and the Declarant. SFR uses adjacent to the ICW shall be  
2 permitted to construct docks in any configuration designated by the Declarant, subject only to  
3 State and Federal permitting requirements. SFR uses adjacent to Bulow Creek shall be  
4 prohibited from constructing docks along Bulow Creek.

Deleted: or Bulow Creek

5 (b) Town House: This use permits two or more attached or shared wall single-  
6 family units. Town House may include fee simple or condominium ownership models. Town  
7 House units may be constructed with one car garages, so long as minimum parking standards  
8 are met. In addition, duplex homes under single ownership are permitted.

9 (c) Multi-family: The purpose of the multi-family use is to provide areas for  
10 attached housing, and medium-density to high-density apartments or condominiums. These  
11 uses also allow for assisted living or nursing homes.

12 (d) Commercial: This use is to provide areas for general commercial and office  
13 uses to meet the community-wide demand for retail, services, business, and employment  
14 opportunities. Specific uses are provided by the City Ordinance 2024-06 with additional  
15 permitted uses being amphitheaters, farmers markets, mooring docks and marina facilities.  
16 Commercial uses may also include residential uses to establish mixed-use neighborhood nodes  
17 consistent with Section 16, below.

18 (e) Mixed-Use: This use supports economic development by providing a specific,  
19 defined location where multiple opportunities for working, shopping, entertainment, lodging,  
20 and living are provided. Recognizing that Tracts may include both commercial and residential  
21 uses, the mixed-use allows for designs to integrate commercial and residential (attached or  
22 detached) uses to achieve this goal. For example, mixed-use allows for buildings to provide  
23 commercial uses on the first floor with residential above.

1 (f) Conservation: This use allows areas within the Project to generally remain in  
2 their natural vegetative state upon which development may proceed with restrictions. The  
3 use permitted to be developed in Conservation areas are restricted to: 1) open space parks,  
4 2) recreation areas, 3) public facilities/utilities, and 4) uninhabitable structures. The  
5 Conservation use designation shall be permitted on any Tract despite not being designated  
6 in the table above.

7 **SECTION 7. VEHICULAR/NON-VEHICULAR AND PEDESTRIAN ACCESS, AND**  
8  
9 **INTERCONNECTIVITY.**

10 (a) The MPD Master Plan integrates pedestrian, bicycle, and vehicular traffic  
11 circulation systems within the Project and within adjacent right-of-way(s). All uses shall have  
12 access to a roadway or shared driveway(s) and may, but are not required to, front on a dedicated  
13 road. The City, but not the general public, shall be granted access at all times to all private  
14 roadways to ensure that public safety is maintained.  
15

16 (b) During the subsequent design and development stage of the Project, the  
17 Declarant shall coordinate with the Flagler County School District for a school bus stop  
18 location.

19 (c) As depicted on the MPD Master Plan, the Spine Road (*defined below*) shall be  
20 a public right-of-way. The MPD Master Plan depicts various Tracts intended for development  
21 accessing the Spine Road, the final location of such is at the sole discretion of the Declarant.  
22 The Spine Road shall be designed and constructed to also accommodate pedestrian traffic for  
23 the benefit of the general public, and as generally depicted on **Exhibit "E"**.

24 (d) Vehicular and pedestrian access from the Project to Palm Drive shall be  
25 expressly prohibited.

Deleted: ¶

1 **SECTION 8. LAND DEVELOPMENT CODE PARTIAL NON-APPLICABILITY.**

2  
3 The development of the Project shall proceed in accordance with the terms of this  
4 Development Agreement. In the event of a conflict between the terms of this Development  
5 Agreement and the MPD Master Plan, the provisions of this Development Agreement shall  
6 prevail. In the event of an inconsistency or conflict between the terms of this Development  
7 Agreement and the LDR, the terms and provisions of this Development Agreement shall prevail.  
8 Where specific requirements are not contained in this Development Agreement, the LDR shall  
9 apply to the extent that it does not conflict with the provisions of this Development Agreement  
10 or the general intent of the MPD Master Plan. Moreover, the Parties agree that the City's LDR  
11 (2024) shall be applied and any subsequent changes to such shall have no effect unless the  
12 Declarant elects, at its sole discretion, to comply with such change to the LDR.

13 **SECTION 9. FACILITY COMMITMENTS.**

14 (a) Unless provided elsewhere in this Development Agreement or other agreement,  
15 the Declarant agrees that the City is not responsible for the construction or creation of public  
16 facilities or capacity to facilitate the development of the Subject Property. As a material  
17 inducement for entering into this Agreement, the City represents and warrants that it presently  
18 has and shall maintain potable water and wastewater capacity for the Project, each of which is  
19 estimated to be 850,000 gallons per day, and the failure to provide such shall be deemed a  
20 breach of this Agreement subject to damages. Therefore, the City shall reserve sufficient  
21 potable, wastewater, and reuse water capacity for the Project, and if such reservation cannot  
22 be immediately satisfied by the City when requested by the Declarant, the Parties agree that  
23 the Declarant may, at its sole discretion and without objection from the City, construct private  
24 services or obtain such services from other providers including adjacent municipalities.

1 (b) Private & Public Improvements: The Declarant agrees to construct the  
2  
3 following on-site improvements at the Declarant’s sole and exclusive expense as a condition  
4 of this Development Agreement, and in addition to the payment of all impact fees relating to  
5 the development of the Subject Property, unless otherwise provided for herein:

6 i. Private Improvements: The parking areas; utilities; master stormwater  
7 system; sidewalks; lighting; recreational facilities, and perimeter buffer landscaping.

8 ii. The Declarant agrees that the City has shown an essential nexus between  
9 a legitimate City interest and the conditions, if any, imposed herein. The Declarant further agrees  
10 that all proposed conditions are roughly proportional to the impact the development will have  
11 upon the public, based upon an individualized determination by the City that the required  
12 conditions are related in both nature and extent to the impacts of the proposed Project.

13 iii. Nothing herein shall be deemed a prohibited exaction under *Florida*  
14 *Statutes*, Section 70.45, and Declarant agrees it has not suffered any damages under that statute.

15 (c) Sidewalks and Pedestrian Paths: The Declarant shall provide an internal  
16 integrated system of sidewalks to ensure that pedestrians maintain access to all uses. The  
17 Declarant shall require homeowners to construct community sidewalks a minimum of five (5)  
18 feet wide on at least one side of the internal roadway system, as may be determined by the  
19 Declarant. In addition, the Declarant may provide stabilized pedestrian trails in other areas of  
20 the Project, as permitted by governmental permits for the purpose of providing recreational  
21 opportunities, connectivity and open space. Moreover, the Declarant shall construct an eight  
22 foot (8’) multi-use trail along the Spine Road connecting SR100 to John Anderson Highway  
23 as generally depicted on the MPD Master Plan and **Exhibit “E”**.  
24

25 (d) Access: Ingress and egress to the Project shall be provided, constructed, and

1 dedicated to the City as a public roadway between SR100 and John Anderson Highway, as  
2 generally depicted on the MPD Master Plan (the “Spine Road”). Prior to dedication, at the  
3 Declarant’s sole discretion, Declarant (or its assigns) may reserve an easement over the Spine  
4 Road for purposes of signage, enhanced landscape maintenance, Tract access and construction.  
5 Moreover, the development of Tracts may be gated from the Spine Road and other public rights  
6 of way. The cost of design and construction of the Spine Road shall be eligible for  
7 transportation impact fee credits on a dollar-for-dollar basis.

8 ~~(e) Spine Road Construction.~~ If after the 600<sup>th</sup> ~~single family residential unit is~~  
9 completed within the residential areas of Veranda Bay the construction of the Spine Road  
10 connection from State Road 100 to John Anderson Highway ~~is not completed~~, no further building  
11 permits will be issued for new home construction until the Spine Road construction is complete.

Deleted: (i)  
Deleted: home  
Deleted: ,  
Deleted: has not commenced,

12 (f) Stormwater System: The Declarant shall be responsible for designing,  
13 permitting, constructing, and maintaining the means of conveyance of stormwater runoff within  
14 the Project including, but not limited to, all stormwater lines, ditches, culverts, and other  
15 stormwater facilities that are necessary to convey and treat stormwater runoff (the “Stormwater  
16 System”), as generally depicted on **Exhibit “F”**. This is graphical in nature, subject to change and  
17 intended to only provide a conceptual model subject to final permitting including but not limited  
18 to the City’s preliminary plat approvals.

19 (g) Parks And Recreation: Given (i) the prior conveyance of the Public Lands,  
20 including the public boating facility land to Flagler County, and (ii) the active and passive recreational  
21 obligations found herein, the Project satisfies the City’s Comprehensive Plan and the City’s  
22 recreational level of service. Notwithstanding, the Declarant shall provide one or more active  
23 recreational facilities west of John Anderson Highway for the benefit of the Project’s residents.

1 Declarant will cooperate with Flagler County to provide public park access to Bulow Creek in the  
2 southwest portion of the Project through the parcel currently owned by the County or an equivalent  
3 property. A maximum of three (3) docks or viewing platforms shall be permitted on Bulow Creek  
4 subject to state, federal and county approval.

5 In addition to the above, the Declarant shall dedicate and convey to the City: (i) a four (4) acre  
6 park site with direct access to John Anderson Highway, and (ii) Two (2) one acre park sites with  
7 direct access to the Spine Road and the multiuse trail constructed by the Declarant.

Formatted: Indent: First line: 0.5"

8 (h) Community Development Districts: The City agrees and acknowledges that  
9 the Annexed Property is subject to the Gardens at Hammock Beach Community Development  
10 District, Flagler County, Florida ("District"), Chapter 190, *Florida Statutes*, which was  
11 initially established by Flagler County. The City agrees that it shall accept and acknowledge  
12 the powers granted to the District pursuant to State law. The City agrees to execute all  
13 documents that may be necessary or take any action necessary to transfer the local government  
14 jurisdiction to the City, to the extent such may be necessary. In addition, the City agrees and  
15 acknowledges that it will, in good faith, assist the Declarant, at Declarant's sole discretion, to  
16 amend the District's existing boundaries. The City shall, at the request of the Declarant, assist  
17 the Declarant to establish an additional community development district governing that portion  
18 of the Annexed Property west of John Anderson Highway, which shall be permitted to finance,  
19 fund, plan, establish, acquire, construct, enlarge or extend, equip, operate and maintain  
20 projects, systems and facilities for the purposes described in Section 190.012, *Florida Statutes*,  
21 including but not limited to, any transportation improvements that may be required by this  
22 Development Agreement or other permit.

23 (i) Agriculture/Silviculture: The Subject Property has been and will continue to  
24

1 be used for silviculture purposes. Silviculture activities may continue to occur on the Subject  
2 Property until that portion of the Subject Property approved for development obtains all  
3 necessary permits and construction commences. All silviculture activities shall continue to  
4 comply with all Federal and State requirements. All silviculture activities shall comply with  
5 the State of Florida Division of Forestry Best Management Practices. The Subject Property  
6 shall therefore remain eligible for all agricultural exemptions as provided by law.

7 **SECTION 10. DEVELOPMENT STANDARDS.**

Formatted: No underline, Condensed by 0.1 pt

8 (a) **Parking:** Parking requirements for each Tract shall be consistent with the LDR, unless  
9 provided for elsewhere in this MPD Agreement. The calculation of minimum parking space  
10 requirements for the development of any Tract or subsequently platted lot may include excess parking  
11 spaces from another Tract or lot, so long as the aggregate number of parking spaces required for both  
12 is satisfied. Additionally, the Declarant may have shared parking facilities serving more than one use  
13 or Tract, only if the Declarant provides analysis from a traffic engineer that the different uses or  
14 mixed-uses will have different peak hour parking demands and sufficient parking will be provided as  
15 required by the LDR. The calculation of minimum parking space requirements for the development  
16 of any Tract may be determined by the Declarant, subject to the recommendation of a duly licensed  
17 traffic engineer. Multi-family developments shall require 1.75 parking spaces/unit or more, as  
18 determined by the Declarant.  
19

20 (b) **Open Space:** Minimum open space shall be 359.6 acres [forty percent (40%)] of the  
21 Project in its entirety including a minimum of 90.42 acres of conservation and 45 acres of  
22 landscape/wetland buffers. Tracts may be developed with less open space, so long as the  
23 aforementioned requirement for the Project is maintained. Open space is defined by Ordinance 2024-  
24 06 and the flexibility defined therein shall be approved by the Land Use Administrator. Open space

Deleted: .



1 shall be maintained by either the Community Development District, a property owners association, a  
2 mutually agreeable conservation easement, or other method satisfactory to the Declarant. Based on  
3 the obligations of this Development Agreement and the prior conveyance of the Public Lands, the  
4 City’s open space requirements provided in its Comprehensive Plan, LDR and other regulations is  
5 satisfied.

6 (c) Water/Wastewater/Reuse: The Declarant shall convey all on site water, waste  
7 water and reuse improvements being served by the City to the City, pursuant to the City’s  
8 standard utility agreement. The City shall not charge fees to a community development district  
9 or a property owners association for the use of City reuse water for common areas until January  
10 1, 2034.

12 (d) Transportation: The Parties accept the traffic study performed by Chindalur  
13 Traffic Solutions, Inc. (the “Transportation Study”), including its conclusions which are  
14 incorporated herein by reference. Notwithstanding, the Declarant shall be obligated to comply  
15 with Florida Department of Transportation requirements for its impacts to SR100. As for  
16 impacts to John Anderson Highway, the Declarant shall construct improvements as provided  
17 in the Transportation Study and as depicted on the MPD Master Plan (“Traffic Improvements”)  
18 at such time as deemed necessary in the Transportation Study. The Declarant shall be obligated  
19 for all the cost of design, permitting and construction of all required Traffic Improvements  
20 identified in the Transportation Study. The Project shall be deemed vested and no additional  
21 off site transportation improvements shall be required to be constructed by the Declarant.

22 (e) Drainage: The Declarant shall construct and maintain a stormwater  
23 management system that provides treatment and attenuation as required by St. Johns River  
24 Water Management District (SJRWMD) and the LDR. Stormwater piping, swales and ditches  
25

1 shall be designed to convey a five (5) year, twenty-four (24) hour storm event. Stormwater  
2 detention facilities shall be designed to meet the water quality and attenuation requirements of  
3 SJRWMD. Any impact to a flood zone shall be solely regulated by SRJRM, FEMA or other  
4 applicable State and Federal agencies. Permits issued by these agencies shall be determinative  
5 that the proposed impact satisfies any and all City regulations, codes and ordinances, including  
6 but not limited to the City’s Comprehensive Plan. As provided in the Pre-Annexation  
7 Agreement and upon request, the City shall timely cooperate with Declarant to obtain a  
8 CLOMR(s) or LOMAR(s) as issued by FEMA.

9 (f) Landscaping, Tree and Vegetation Protection: Landscaping  
10 requirements adjacent to SR100 and John Anderson Highway shall be subject to this  
11 Development Agreement and the LDR. All other landscaping design and requirements shall  
12 comply with those standards provided in Exhibit “T” which may be amended from time to  
13 time. ~~No potable water shall be used for irrigation after sufficient stormwater or reclaimed~~  
14 ~~water source becomes available in adequate quantities. Efforts to preserve and enhance the~~  
15 Project’s design will be achieved, by the Declarant, through adjustments of building, parking,  
16 roadway and stormwater locations and through supplemental landscaping that will blend with  
17 the natural look yet carefully accentuate the residential areas, entrances, and other common  
18 spaces. General landscaping around parking lots, roadways, entrances, residential and  
19 commercial buildings, and other common areas will be landscaped with ornamental and native  
20 plant materials when possible. Within residential common areas, fifty percent (50%) of the  
21 total planted vegetation, by aerial extent, shall consist of native, drought-tolerant or waterwise  
22 vegetation. Native or drought-tolerant plants include those in the SJRWMD’s Waterwise  
23 Florida Landscapes, the Florida Native Plant Society’s list of native landscape plants for  
24

Formatted: Indent: Left: 0.08", Space Before: 0.05 pt

Deleted: .

Deleted: ¶

1 Flagler County, A Gardener’s Guide to Florida’s Native Plants (Osorio 2001), or comparable  
2 guidelines prepared by the Florida Department of Agriculture and Consumer Services,  
3 SJRWMD, Florida Fish and Wildlife Conservation Commission or Florida Department of  
4 Environmental Protection. All ornamental landscape beds and lawn areas will have  
5 supplemental irrigation. Flexibility of the MPD Master Plan shall allow for further refinement  
6 of site development, and landscaping.

7 The Declarant shall require (i) three (3) shade trees for each single-family detached  
8 lot and (ii) a shade tree every eighty (80) feet along each side of the Spine Road. Tree and  
9 vegetation protection, removal, conservation, and mitigation requirements shall be governed  
10 by this Development Agreement. In consideration of (i) the approximately 1,100 acres  
11 previously conveyed to the County, (ii) the forty percent (40%) minimum open space required  
12 for the Project as provided in Section 10(b) above, (iii) the Declarant’s significant commitment  
13 herein to extensive landscaping along the Spine Road, (iv) the Declarant’s commitment herein  
14 to require three (3) shade trees for each single-family detached lot, (v) the Declarant’s  
15 commitment herein to incorporate drought-tolerant vegetation and (vi) the Declarant’s  
16 commitment to a significant investment in a reuse water distribution system, the removal of  
17 trees and vegetation shall be allowed to the extent the removal of such is necessary as solely  
18 determined by the Declarant, to provide infrastructure, stormwater, utilities, recreational  
19 opportunities, or finished lots. Mitigation for tree and vegetation removal shall not be required  
20 except as provided in the paragraph below.

Deleted: )

Deleted: ,

Deleted: ¶

21 During the platting process of individual tracts, the Declarant shall provide the City a tree  
22 survey depicting the location of viable oak trees with diameters of thirty-six (36) inches or greater.  
23 The Declarant shall make efforts to protect these oak trees as part of its design and development

Deleted: .

Formatted: Justified, Right: 0.41", Line spacing: Double

1 of individual tracts. If the Declarant determines that it is necessary to remove an oak tree thirty-  
2 six (36) inches or greater in diameter, the removal shall be permitted and the Declarant shall  
3 provide mitigation as calculated by the City's LDR. All other trees, including but not limited to  
4 all species of pine trees, may be removed without mitigation.

Deleted: ¶

5 A Community Development District or Property Owners Association or Home Owners  
6 Association shall be permitted to use temporary wells for the Project's irrigation until sufficient  
7 reuse is available subject only to permits issued by the state or federal agencies.  
8 Notwithstanding the foregoing, private wells shall be prohibited on individual single-family  
9 lots.

Deleted: The Declarant, at its option, may erect fences or walls up to eight (8)six (6) feet high along all parts of the perimeter of the Subject Property except for areas in a conservation easement. In addition, a

10 John Anderson Buffer. The Developer shall provide a 25-foot minimum and 50-foot  
11 average buffer along the limits of the Project boundary that coincides with the John Anderson  
12 Highway right of way.

13 (g) Lighting: All lighting, including but not limited to all pole mounted lighting,  
14 shall be designed to minimize light pollution to off-site properties and to comply with the  
15 LDR, unless otherwise agreed to by the LUA. In addition, development within one hundred  
16 feet (100') from Bulow Creek shall use low level lighting shielded from view to minimize its  
17 impact to the natural environment.

Deleted: ¶  
Formatted: Justified, Right: 0.41", Line spacing: Double, Numbered + Level: 1 + Numbering Style: a, b, c, ... + Start at: 1 + Alignment: Left + Aligned at: 0.58" + Indent at: 1.08"

Deleted: be encouraged to

18 (h) Fire Protection: The Declarant previously donated to Flagler County a three (3)  
19 acre parcel of land for a fire station to serve the Project and the residents along John Anderson  
20 Highway. Fire protection requirements for the Project will be met through a system of fire  
21 hydrants installed on the Project by the Declarant in accordance with City standards. The  
22 locations of fire hydrants shall be shown on all construction documents, technical site plans, or  
23 preliminary plats. The Project shall comply with the City's fire protection requirements. The

Formatted: Indent: First line: 0.5", Right: 0.44"

1 City will provide fire protection services to the Project in accordance with established local  
2 response agreements.

3 (i) Utilities: The Declarant shall not be responsible for any costs associated with  
4 the extension of City utilities to the Subject Property that may be required to serve this Project.  
5 Notwithstanding, all City utilities, including water and sewer, constructed in or adjacent to the  
6 Spine Road shall be eligible to receive connection fee credits on a dollar-for-dollar basis.

Formatted: Indent: First line: 0.5", Right: 0.25"

7 (j) Interconnectivity and Access: All units within the Project shall be  
8 interconnected by roadways and sidewalks, as called for by the City's Comprehensive Plan. The  
9 Project shall provide and maintain the minimum number of access drives onto John Anderson  
10 Highway, as generally depicted on the MPD Master Plan.

11 (k) Wetlands: Wetland permitting, including their impacts and/or mitigation, for the  
12 Project may occur and shall only be subject to Federal and States permits which the City shall  
13 accept. The City agrees that any approval, impact or effect to wetlands, wetland buffers, and  
14 wetland setbacks provided by said permits shall be accepted by the City and deemed consistent  
15 with the City's Comprehensive Plan. The Project shall therefore be exempt from Section 4 of the

Formatted: List Paragraph, Left, None, Indent: Left: 0",  
First line: 0.5", Right: 0.21", Numbered + Level: 1 +  
Numbering Style: a, b, c, ... + Start at: 1 + Alignment:  
Left + Aligned at: 0.58" + Indent at: 1.08", Tab stops:  
1.08", Left

16 LDR Bulow Creek Buffer. The Developer will voluntarily provide a 25-foot minimum and 75-  
17 foot average buffer along the limits of the Project boundary that coincides with Bulow Creek. The  
18 Declarant shall also provide a natural buffer no less than seventy-five (75) feet from the edge of  
19 the Bulow Creek river bank. Notwithstanding the foregoing, the minimum setback shall be 75-  
20 feet in those areas as generally depicted in **Exhibit "G"**.

Deleted: ¶  
(i)

Formatted: Font: 12 pt

21 (l) Signage: Signs shall comply with the LDR, unless otherwise provided herein. The  
22 design and intent of signage is to ensure adequate means of communication through signage while  
23 maintaining the attractive visual appearance within the Project. Signage shall meet the following

1 requirements:

2 (i) Gateway Signage and Entrance Features. Signage located at the  
 3 primary entrances to the Project (SR100 and John Anderson Highway) shall have a maximum  
 4 height of twenty (20) feet with a maximum signage area of one hundred sixty (160) square feet. A  
 5 maximum of two (2) gateway signs shall be permitted for any primary entrance. An entrance  
 6 feature may be designed in conjunction with the entrance signage or it may occur separately,  
 7 However, the main entrance to Veranda Bay residential located at the intersection of John  
 8 Anderson and Buena Vista Boulevard may have an entrance feature exceeding twenty (20) feet,  
 9 but no taller than thirty-five (35) feet.

**Formatted:** Indent: Hanging: 0.58", Right: 0.21", Tab stops: 1.56", Left + Not at 1.58"  
**Formatted:** Right: 0.21"

**Deleted:** Any entrance feature shall have a maximum height of twenty (20) feet

11 (ii) Thoroughfare Neighborhood Entrance Signs. Signage located along any  
 12 internal road or at any neighborhood entrance shall have a maximum height of twelve (12) feet  
 13 and a maximum signage area of one hundred (100) square feet. Any entrance features shall have a  
 14 maximum height of twenty (20) feet. However, the main entrance to Veranda Bay residential  
 15 located at the intersection of John Anderson and Buena Vista Boulevard may have an entrance  
 16 feature exceeding twenty (20) feet, but no taller than thirty-five (35) feet.

**Formatted:** Indent: First line: 1.06", Right: 0.21", Tab stops: Not at 1.58"

17 (iii) Commercial Signage. Ground signs shall be permitted for the  
 18 commercial area of the Project with a maximum signage area per sign of three hundred twenty (320)  
 19 square feet and a maximum height of twenty (20) feet. Additional commercial signage and wall  
 20 signage shall be permitted, including signage at the Marina and Intracoastal Waterway.

**Deleted:** thirty (30)

21 (iv) Signage Area. Signage area shall be calculated using the actual text and, if  
 22 applicable, logo graphics area only. Walls or architectural effects shall not count toward the  
 23 signage area square feet restriction, but shall meet the height restrictions set forth above.

24 (v) Entrance Features. Walls, architectural icons, water features, landforms,

1 landscaping, or other effects which announce and signify arrival are permitted for the signage on  
2 the Subject Property. Where a sign is incorporated in an entrance feature, the sign height shall be  
3 measured from the bottom to the top of the sign copy area.

4 (vi) Ground signage provided for in this section shall be permitted be  
5 constructed in the public right of way.

Formatted: Indent: First line: 1.06", Right: 0.21"

6 (m) Temporary Facilities/Model Homes: Temporary support facilities shall be  
7 permitted for a period of ten (10) years, at which time sales offices, model homes, development  
8 trailers and real estate offices shall be transitioned into a permanent use within the Project. This  
9 time period may be extended for successive periods of three (3) years by the LUA. Temporary  
10 support facility approval and extension shall be processed by the LUA. The initial application for  
11 temporary support facilities will be reviewed and approved by City Staff. Following City Staff  
12 approval, a building permit application will be submitted to the City Building Department for  
13 review and approval. Residential units may be used as model homes and sales centers  
14 (collectively, "Model Homes"). Up to five Model Homes can be constructed, occupied, and  
15 operated as sales centers for each Tract of the Project. Sales and leasing activities shall be limited  
16 to properties located within the Project. Construction and Certificates of Occupancies shall be  
17 issued consistent with the City and State rules, regulations, and codes for residential structures.  
18 Model homes shall not be deemed commercial activities. The City shall permit the construction  
19 of Model Homes during the development of a Tract so long as a stabilized subbase of an adjacent  
20 roadway is available.

Formatted: Right: 0.21"

21 (n) Rental Program: Developer reserves the right to place all or any portion of the  
22 Project's units located in zoned Commercial on the MPD Master Plan, in long term, short term,  
23 resort residential, or resort condominium rental programs operated by Declarant, its affiliates or  
24

1 any third-party rental program operators approved by the Declarant. Otherwise, short term  
2 vacation rentals shall be prohibited.

3 (o) Marina: The Marina located on Tract E, shall only be governed by permits  
4 issued by State and Federal agencies. The City agrees that said permits shall be deemed to be  
5 consistent with the City's Comprehensive Plan, the LDR and other City ordinances. The  
6 development of the Marina shall: (i) participate in the FDEP Clean Marina program, and (ii) remain  
7 exempt from Chapter 22, Art IV of the City Code of Ordinances. The Marina may, at Declarant's  
8 sole discretion, include wet and dry slips, transient or permanent slips, fueling facilities, a boat  
9 ramp and any uses permitted as a commercial use. However, dry slips shall be used solely for the  
10 maintenance and repair of boats and not for long-term storage. Subject to the above, the design,  
11 permitting and construction of the Marina shall be exempt from any City code or regulation, except  
12 its fire and building codes.

Formatted: Indent First line: 0.5", Right: 0.21"

13 (p) Age Restrictions: Nothing in the Development Agreement shall prohibit any age  
14 restriction requirements or use permitted by Federal or State law.

Deleted: For purposes of this Agreement dry slips shall be spaces not in or above the water used to park or store marine vessels.

Formatted: List Paragraph, Left, Indent: Left: 0", First line: 0.5", Right: 0.21", Space Before: 0.05 pt, Numbered + Level: 1 + Numbering Style: a, b, c, ... + Start at: 1 + Alignment: Left + Aligned at: 0.58" + Indent at: 1.08", Tab stops: 1.08", Left

15 (q) Accessory Uses: Typical residential accessory uses will be allowed, including but  
16 not limited to: decks, swimming pools, patios, air conditioning units, walkways and sidewalks.  
17 Accessory uses and structures will be allowed in accordance with this Development Agreement,  
18 provided such uses and structures are of a nature customarily incidental and clearly subordinate to  
19 the permitted or principal use of a structure. Accessory uses or structures contained within or  
20 attached to the building containing the principal use shall be considered a part of the principal  
21 building and not an accessory building and shall meet the same requirements for setbacks as the  
22 main use structure. However, pools, covered pools, patios, outdoor fireplaces, decks, and gazebos,  
23 either attached or detached from the principal use structure, may be constructed up to a minimum

Deleted: ¶

Formatted: Indent First line: 0.5", Right: 0.21"



1 of five (5) feet from the rear or side property boundary. In no case shall the water's edge of a  
2 swimming pool be located closer than five (5) feet from the side and rear property line. Air  
3 conditioning and heating units, pool mechanical equipment, utility meters and other mechanical or  
4 utility service features may be located in any required side or rear yard up to a minimum two (2)  
5 foot setback to the property line. No accessory structure, excluding yard ornaments, shall be located  
6 within the required front yard.

7 **SECTION 11. PHASING OF DEVELOPMENT.**

Deleted: ¶

8 (a) The Project may be developed in multiple phases. Prior to the issuance of any  
9 permit for any phase of the Project (and prior to any construction of any improvement,  
10 building, or structure on the Subject Property), the Declarant shall submit a Preliminary Plat  
11 or Site Plan for the relevant phase. Each Tract of the Project will include infrastructure to  
12 support the proposed uses, including water and wastewater service, drainage, private roads,  
13 vehicular, and pedestrian access facilities. All infrastructure necessary to support each phase  
14 that is constructed on the Subject Property shall be constructed concurrently with, or prior to  
15 construction of that phase of the Project, as approved by the City, and prior to the issuance of  
16 building permits for that phase. Adequate emergency vehicle access and turnarounds shall be  
17 provided at all times.

18 (b) Roadways shall be constructed concurrently with development of adjacent lots  
19 to ensure that contiguous roadways are available at all times prior to the issuance of any  
20 building permits for that phase. To avoid unnecessary construction and repair costs, internal  
21 sidewalks shall be constructed adjacent to each residential lot at the time the home is  
22 constructed and prior to the Certificate of Occupancy, and each home's building permit shall  
23 be conditioned on this requirement. Model Homes shall be exempt from this standard until no

1 longer being used as such at which time the owner shall construct the required sidewalk.

2 (c) The City may issue permits for clearing, grading and earthwork for portions of  
 3 the Subject Property before approving final construction plans, however, all Federal and State  
 4 permits relating to land clearing, grading and earthwork must be obtained.

5  
 6 **SECTION 12. LOT AND BUILDING STANDARDS.**

7 (a) Lot Dimensional Standards: Dimensional standards for each use shall comply  
 8 with the LDR except as follows:

9

<u>Type</u>	<u>SF</u>	<u>Multi-family</u>	<u>Town House</u>	<u>Multi-family Marina</u>
<b>Min. Distance Between Buildings***</b>	10'	10'	10'	10'
<b>Min. Bldg. Setback to Water</b>	20'	20'	20'	10'
<b>Max. Bldg. Height****</b>	35'	35'	35'	35'
<b>Min. Front Bldg. Setback to Property Line</b>	15'	15'	10'	10'
<b>Min. Bldg. Rear Yard Setback</b>	10'	10'	10'	10'
<u>Type</u>	<u>SF</u>	<u>Multi-family</u>	<u>Town House</u>	<u>Multi-family Marina</u>
<b>Minimum Front Setback from Right of Way</b>	20'	N/A	20'	N/A
<b>Minimum Bldg. Side Street or Rear Yard Setback</b>	10'	10'	10'	10'
<b>Min. Lot Size (SF)</b>	4,000 sf	N/A	1,600 sf	N/A
<b>Minimum Lot Width</b>	40'	N/A	16'	N/A
<b>Max. Impervious Surface Ratio**</b>	70%	80%	80%**	80%**

10  
 11  
 12 \*Except as provided in Section 10, above.

1       \*\*Maximum Floor Area and Impervious Surface Ratios shall be applicable to each Tract.  
 2       \*\*\* Shall be measured as the distance between walls of adjacent structures.  
 3       \*\*\*\* In the event the City increases its max building height limitations, the Declarant may elect to increase its maximum building height to  
 4       such new limit. Notwithstanding, residential structures presently under construction or constructed may exceed this height limitation.  
 5  
 6  
 7  
 8  
 9  
 10  
 11  
 12

13       **Commercial or Mixed-Use with Residential Above Commercial**  
 14       **Site Development Requirements**  
 15

<b>Min. Lot Width</b>	<b>80'****</b>
<b>Min. Lot Size</b>	<b>12,000 sf</b>
<b>Min. Bldg. Side Setback</b>	<b>0'</b>
<b>Min. Bldg. Street-Side Setback</b>	<b>10'</b>
<b>Min. Bldg. Front Setback</b>	<b>10'</b>
<b>Max. Bldg. Height****</b>	<b>35'</b>
<b>Min. Bldg. Rear Setback</b>	<b>10'</b>
<b>Minimum Bldg. Setback to MPD Property Line</b>	<b>20'</b>
<b>Maximum Floor Area Ratio*</b>	<b>100%</b>
<b>Max. Impervious Surface Ratio*</b>	<b>80%**</b>

16       \* Maximum Floor Area and Impervious Surface Ratios shall be applicable to each Tract.  
 17       \*\*Minimum open space shall be forty percent (40%) of the entire MPD gross area.  
 18       \*\*\* If Town Houses are developed within a Commercial District, the dimensional standards for Town Houses shall control.  
 19       \*\*\*\* In the event the City increases its max building height limitations, the Declarant may elect to increase its maximum building height to  
 20       such new limit.  
 21  
 22

Deleted: ¶  
 ¶  
 ¶  
 ¶  
 ¶

23       (b) Mixed-Use Dimensional Standards: If a mixed-use is being developed for both  
 24       residential and commercial uses on the same Lot then the dimensional standards for the  
 25       dominant use shall be utilized (residential or commercial uses having the most building gross  
 26       floor area), unless commercial uses are on the first floor and the residential uses are on above  
 27

1 floor(s), then the standards in the above table shall be used. Any conflict in dimensional or  
2 design standards for a mixed-use development may be resolved by the Land Use  
3 Administrator.

4 (c) Architecture: All architectural standards and requirements shall be determined,  
5  
6 approved and enforced by the Declarant. Notwithstanding, commercial architectural requirements  
7 shall be governed by the City's LDR.  
8

9  
10 **SECTION 13. LIST OF OUTSTANDING PERMITS/APPROVALS AND PROPER**  
11 **SEQUENCING.**

12  
13 (a) The failure of the Development Agreement to address any specific State or  
14 Federal permit, condition, term, or restriction shall not relieve the Declarant of the requirement  
15 of complying with the law governing said permitting requirements, conditions, terms, or  
16 restrictions.

17 (b) All required City, County, State, or Federal permits shall be obtained prior to  
18 commencement of construction. This Development Agreement is not a Preliminary Plat approval,  
19 and the Declarant remains responsible for complying with all provisions of the LDR, unless provided  
20 elsewhere in this Development Agreement. The subdivision of the Subject Property to provide for  
21 any Tract shall not require platting as required by Chapter 177, *Florida Statutes*, and therefore the  
22 Declarant may convey a Tract by metes and bounds and without platting.

23 (c) Burning: Open burning shall be prohibited during development and property  
24 owners shall be subject to the City's LDR.

25 **SECTION 14. DEVELOPMENT FEES.**

26 The Declarant acknowledges and agrees that the City has enacted citywide impact fees,  
27 and may in the future increase the amount of those fees. The Declarant acknowledges that the

1 Project shall be subject to all fees in effect at the time of permitting. Notwithstanding the above,  
2 the Declarant shall not be charged impact fees for the marina wet slips or dry slips.

3 **SECTION 15. COMMON AREAS AND MAINTENANCE.**

4 To ensure the long-term maintenance and control of common areas, the Declarant shall  
5 dedicate such areas to (i) the existing community development district, (ii) a property owners  
6 association or (iii) other entity accepted by the LUA (collectively the “Association”).

8 **SECTION 16. CONVERSION OF USES.**

9 The Declarant may increase or decrease the amount of a particular land use without modifying  
10 or amending this Development Agreement or the MPD Master Plan, but only within the minimum  
11 and maximum standards provided for on the Land Use Conversion Matrix attached as **Exhibit “H”**,  
12 provided that (i) the changes are consistent with the Land Use Conversion Matrix and (ii) at the time  
13 of election of a land use conversion under the Land Use Conversion Matrix, the Declarant shall notify  
14 the City of the conversion in writing at least thirty (30) days in advance of the conversion. Any  
15 modification to this Development Agreement shall incorporate all changes previously made pursuant  
16 to the Land Use Conversion Matrix prior to the filing of such modification. Provided that the  
17 conversion is (i) consistent with the criteria contained in the Land Use Conversion Matrix attached as  
18 **Exhibit “H”**, and (ii) such converted uses are consistent with the uses allowed under by this  
19 Development Agreement. Notwithstanding the foregoing, any change or deviation from the approved  
20 land uses provided for herein shall be consistent with the City’s Comprehensive Plan, which may  
21 require a small scale comprehensive plan amendment as more particularly described in Section  
22 163.3187, Florida Statutes.

24 **SECTION 17. BREACH, ENFORCEMENT, ALTERNATIVE DISPUTE AND**  
25 **CONFLICT RESOLUTION.**

1  
2 (a) In the event of a breach of this Agreement by either Party, the other party hereto  
3 shall have all rights and remedies allowed by law, including the right to specific performance  
4 of the provisions hereof.

5 (b) In the event that a dispute arises between the Parties, the City and Declarant  
6 shall attempt to resolve all disputes informally and if they cannot, the Parties agree to engage  
7 in pre-suit mediation before a certified Circuit Court mediator selected by the Parties within  
8 thirty (30) days of either party making a written request to the other. If the Parties fail to agree  
9 to a mediator, a certified mediator will be selected solely by the City. The Parties shall equally  
10 pay all costs of mediation.

11 **SECTION 18. NOTICES.**

12 (a) All notices required or permitted to be given under this Development  
13 Agreement must be in writing and must be delivered to the City or the Declarant at its address  
14 set forth below (or such other address as may be hereafter be designated in writing by such  
15 party).

16 (b) Any such notice must be personally delivered, sent by certified mail, or  
17 overnight courier

18 (c) Any such notice will be deemed effective when received (if sent by hand  
19 delivery receipt required,) or on that date which is ten (10) days after such notice is deposited  
20 in the United States mail (if sent by certified mail).

21 (d) The Parties' addresses for the delivery of all such notices are as follows:

22  
23 As to the City: City Manager  
24 City of Flagler Beach  
25 City Hall  
26 105 S. 2<sup>nd</sup> Street

Ordinance No. 2024  
-  
Page 29 of 37

1 Flagler Beach, FL 32136

2  
3  
4  
5  
6  
7  
8  
9  
10  
11  
12  
13

As to the Declarant: PALM COAST INTRACOASTAL,  
LLC, Attn: Kenneth Belshe  
3129 SPRINGBANK LN 201  
CHARLOTTE, NC 28226

With copies to: Michael D. Chiumento III, Esq.  
Chiumento Law, PLLC  
145 City Place, Suite 301  
Palm Coast, FL 32164

14 **SECTION 19. SEVERABILITY.**

15  
16  
17  
18  
19

The terms and provisions of this Development Agreement are not severable. However,  
in the event any portion of this Development Agreement shall be found to be invalid or illegal,  
then the remaining portions of the Development Agreement shall remain valid and binding on  
the Parties.

20 **SECTION 20. SUCCESSORS AND ASSIGNS.**

21  
22  
23  
24  
25

This Development Agreement and the terms and conditions hereof shall be binding upon and  
inure to the benefit of the City and Declarant and their respective successors-in-interest. The terms  
and conditions of this Development Agreement similarly shall be binding upon the Subject Property  
and shall run with the land and the title to the same.

(b) This Development Agreement touches and concerns the Subject Property.

(c) The Declarant has expressly covenanted and agreed to this provision and all other  
terms and provisions of this Development Agreement.

29 **SECTION 21. GOVERNING LAW, VENUE AND COMPLIANCE WITH LAW.**

30  
31  
32  
33

(a) This Development Agreement shall be governed by and construed in  
accordance with the laws of the State of Florida.

1 (b) Venue for any dispute shall be in the Seventh Judicial Circuit Court in and for  
2 Flagler County, Florida, or the Middle District if in Federal court.

3 (c) The Declarant shall fully comply with all applicable State, and Federal  
4 environmental regulations and all other laws of similar type or nature.

5 (d) If State or Federal laws are enacted after execution of this Development  
6 Agreement which are applicable to and preclude the Parties' compliance with this  
7 Development Agreement, this Development Agreement shall be modified as necessary to  
8 comply with the relevant law.

9

10 **SECTION 22. TERM/EFFECTIVE DATE.**

11 (a) This Development Agreement shall be effective upon approval by the City  
12 Commission and execution of this Development Agreement by all Parties (the "Effective  
13 Date").  
14

15 (b) This Development Agreement will expire 30 years from the Effective Date  
16 unless renewed in writing by the Parties.

17 **SECTION 23. RECORDATION.**

18 Upon approval by the City Commission and execution of this Development Agreement  
19 by all Parties, this Development Agreement and any and all amendments hereto shall be  
20 recorded by the City with the Clerk of the Circuit Court of Flagler County within fourteen (14)  
21 days after its execution by the City, and the Development Agreement shall run with the land.  
22 The Declarant shall pay the costs to record this Development Agreement.  
23

24 **SECTION 24. THIRD PARTY RIGHTS.**

25



1 This Development Agreement is not a third-party beneficiary contract, and shall not  
2 in any way whatsoever create any rights on behalf of any third party.

3 **SECTION 25. SPECIFIC PERFORMANCE / TIME IS OF THE ESSENCE.**

4 (a) Strict compliance shall be required with each and every provision of this  
5 Development Agreement. The Parties agree that each has the remedy of specific performance  
6 of these obligations.  
7

8 (b) Time is of the essence to this Development Agreement and every right or  
9 responsibility required herein shall be performed within the times specified.  
10

11 **SECTION 26. ATTORNEYS' FEES.**

12 In the event of any action to enforce the terms of this Development Agreement, the  
13 prevailing party shall be entitled to recover reasonable attorneys' fees, paralegals' fees, and all  
14 costs incurred, whether the same be incurred in a pre-litigation negotiation, litigation at the  
15 trial, or appellate level.  
16

17 **SECTION 27. FORCE MAJEURE.**

18 The Parties agree that in the event that the failure by either party to accomplish any  
19 action required hereunder within a specific time period ("Time Period") constitutes a default  
20 under terms of this Development Agreement, and if any such failure is due to any unforeseeable  
21 or unpredictable event or condition beyond the control of such party, including, but not limited  
22 to: acts of God, acts of government authority (other than the City's own acts), acts of public  
23 enemy or war, terrorism, riots, civil disturbances, power failure, shortages of labor or materials,  
24 injunction or other court proceedings beyond the control of such party, or severe adverse  
25

1 weather conditions (“Uncontrollable Event”); then notwithstanding any provision of this  
2 Development Agreement to the contrary, that failure shall not constitute a default under this  
3 Development Agreement and any Time Period prescribed hereunder shall be extended by the  
4 amount of time that such party was unable to perform solely due to the Uncontrollable Event.

5 **SECTION 28. INDEMNIFICATION.**

6 The Declarant shall indemnify and save the City harmless from and against any and all  
7 damages caused solely by the Declarant’s development of the Subject Property as provided in  
8 this Development Agreement. This provision shall exclude any damages arising out of a third  
9 party challenging this Development Agreement or any subsequent development order issued  
10 by the City affecting the Subject Property as defined by State statute.

11 **SECTION 29. ENFORCEMENT: CITY’S RIGHT TO TERMINATE DEVELOPMENT**  
12 **AGREEMENT.**

13  
14  
15 (a) This Development Agreement shall continue to be enforceable, unless lawfully  
16 terminated, notwithstanding any subsequent changes in any applicable law.

17 (b) The failure by the Declarant to perform its material obligations hereunder shall  
18 constitute a default, entitling the City to pursue whatever remedies are available to it under  
19 Florida law or equity, including, without limitation, an action for specific performance and/or  
20 injunctive relief, or alternatively, the termination of this Development Agreement. Prior to the  
21 City filing any action or terminating this Development Agreement as a result of a default under  
22 this Development Agreement, the City shall first provide the Declarant written notice of said  
23 default. Upon receipt of said notice, the Declarant shall be provided a ninety (90) day period  
24 in which to cure the default to the reasonable satisfaction of the City prior to the City filing an

1 action or terminating this Development Agreement. If ninety (90) days is not considered by  
2 the Parties to be a reasonable period in which to cure the default, the cure period shall be  
3 extended to such cure period acceptable to the City, but in no case shall that cure period exceed  
4 one hundred and eighty (180) days from initial notification of default. Upon the judicial  
5 termination of the Development Agreement, the Declarant shall immediately be divested of all  
6 rights and privileges granted hereunder.

7 **SECTION 30. CAPTIONS.**

8  
9 Sections and other captions contained in this Development Agreement are for reference  
10 purposes only and are in no way intended to describe, interpret, define, or limit the scope,  
11 extent or intent of this Development Agreement, or any provision hereof.

12 **SECTION 31. EXHIBITS.**

13 Each exhibit referred to and attached to this Development Agreement is an essential part of  
14 this Development Agreement. The exhibits and any amendments or revisions thereto, even if not  
15 physically attached hereto, shall be treated as if they are part of this Development Agreement

16 **SECTION 32. INTERPRETATION.**

17  
18 (a) The Declarant and the City agree that all words, terms and conditions contained  
19 herein are to be read in concert, each with the other, and that a provision contained under one  
20 (1) heading may be considered to be equally applicable under another in the interpretation of  
21 this Development Agreement.

22 (b) This Development Agreement shall not be construed more strictly against either  
23 party on the basis of being the drafter thereof, and both Parties have contributed to the drafting  
24 of this Development Agreement.

25 **SECTION 33. FURTHER ASSURANCES.**

Ordinance No. 2024

1  
2 Each party agrees to sign any other and further instruments and documents consistent  
3 herewith as may be necessary and proper to give complete effect to the terms of this  
4 Development Agreement.

5 **SECTION 34. COUNTERPARTS.**

6  
7 This Development Agreement may be executed in any number of counterparts, each of  
8 which shall be deemed an original, but all of which, taken together, shall constitute one (1) and  
9 the same document.

10 **SECTION 35. MODIFICATIONS, AMENDMENTS AND NON-WAIVER.**

11  
12 (a) Unless provided for in Section 5, above: (1) Amendments to and waivers of the  
13 provisions herein shall be made by the Parties only in writing by formal amendment, and (2)  
14 This Development Agreement shall not be modified or amended except by written agreement  
15 executed by all Parties hereto and upon approval of the City.

16 (b) Failure of any party hereto to exercise any right hereunder shall not be deemed  
17 a waiver of any such right and shall not affect the right of such party to exercise at some future  
18 date any such right or any other right it may have.

19 **SECTION 36. ENTIRE AGREEMENT AND EFFECT ON PRIOR AGREEMENTS.**

20  
21 This Development Agreement constitutes the entire agreement between the Parties and  
22 supersedes all previous oral discussions, understandings, and agreements of any kind and  
23 nature, as between the Parties relating to the subject matter of this Development Agreement.

24  
25

26  
27 *(SIGNATURES INTENTIONALITY TO NEXT PAGE)*

IN WITNESS WHEREOF, the Parties have executed this Development Agreement on the dates set forth below.

CITY OF FLAGLER BEACH, FLORIDA

\_\_\_\_\_  
\_\_\_\_\_, Mayor

ATTEST:

\_\_\_\_\_  
\_\_\_\_\_, City Clerk

APPROVED AS TO FORM AND LEGALITY:

\_\_\_\_\_  
\_\_\_\_\_, Esq.

City Attorney

The foregoing instrument was acknowledged before me by means of  physical presence or  online notarization, this \_\_\_\_\_ day of \_\_\_\_\_, 2024, by \_\_\_\_\_, Mayor of the CITY OF FLAGLER BEACH, who is personally known to me.

\_\_\_\_\_  
Notary Public – State of Florida  
Print Name: \_\_\_\_\_  
My Commission expires:

WITNESSES:

“DECLARANT”  
PALM COAST INTRACOASTAL, LLC

By: \_\_\_\_\_  
William G. Allen, Jr., Manager

\_\_\_\_\_  
(print)

\_\_\_\_\_  
\_\_\_\_\_

(print)

STATE OF \_\_\_\_\_

COUNTY OF \_\_\_\_\_

The foregoing instrument was acknowledged before me by means of  physical presence or  online notarization, this \_\_\_\_\_ day of \_\_\_\_\_, 2024, by William G. Allen, Jr., Manager, of Palm Coast Intracoastal, LLC, a Florida limited liability company, (check one)  who is personally known to me or  who produced \_\_\_\_\_ as identification.

\_\_\_\_\_  
Notary Public – State of Florida  
Print Name: \_\_\_\_\_  
My Commission expires:

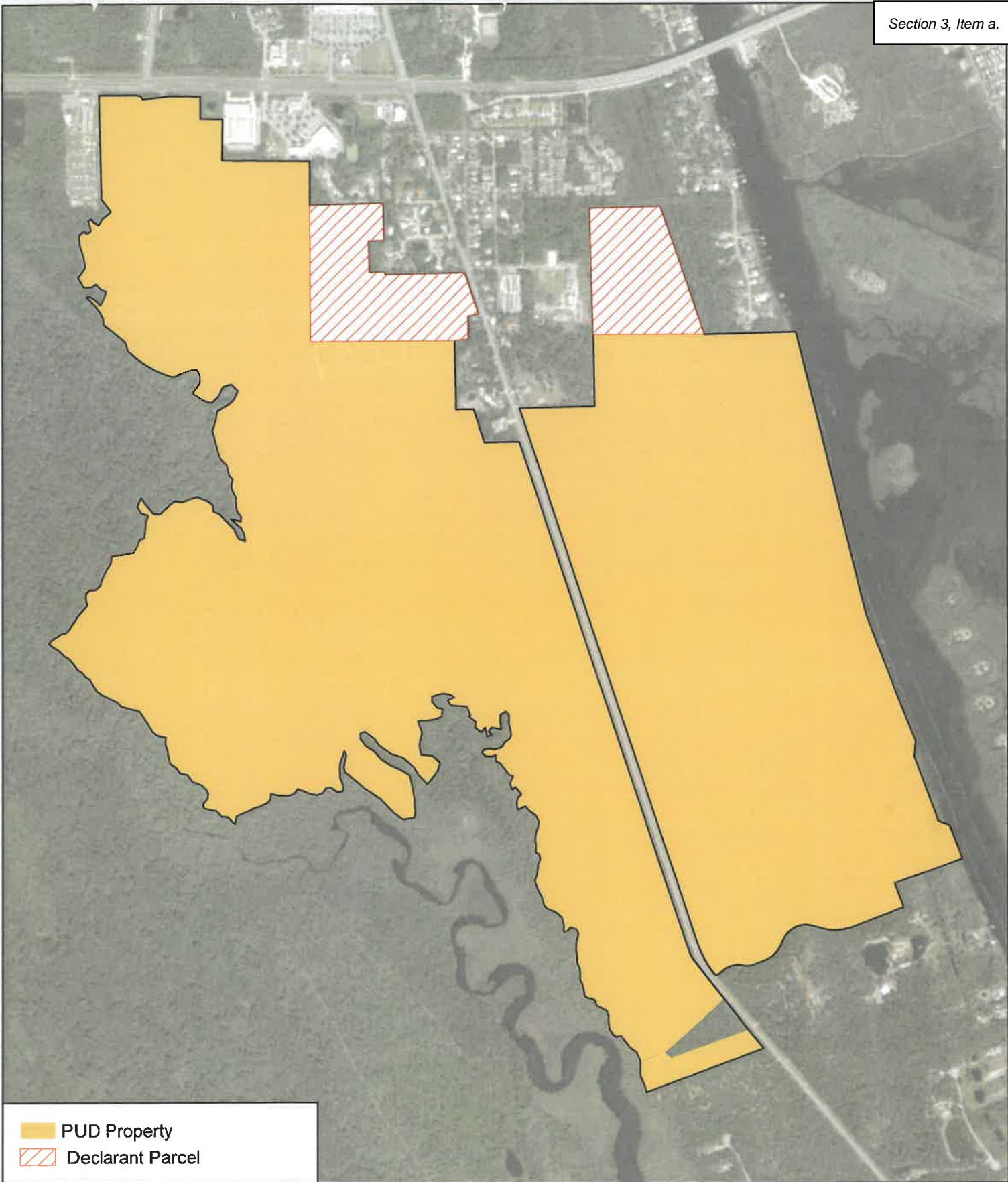

Exhibit "A"

Subject Property  
Veranda Bay  
Flagler County, Florida



**SUBJECT PROPERTY**

A PORTION OF LOTS 1, 3, 7, 8 AND 9, AND ALL OF LOTS 4, 10, 11 AND 12, BLOCK C, BUNNELL DEVELOPMENT COMPANY'S LAND AS RECORDED IN PLAT BOOK 1, PAGE 1, IN THE PUBLIC RECORDS OF FLAGLER COUNTY, FLORIDA, TOGETHER WITH A PORTION OF GOVERNMENT SECTION 14, 38, AND 39, TOWNSHIP 12 SOUTH, RANGE 31 EAST, FLAGLER COUNTY, FLORIDA, SITUATED IN GOVERNMENT SECTIONS 11, 14, 38 AND 39, TOWNSHIP 12 SOUTH, RANGE 31 EAST, FLAGLER COUNTY, FLORIDA, BEING MORE PARTICULARLY DESCRIBED AS FOLLOWS:

COMMENCE AT THE INTERSECTION OF THE EAST RIGHT OF WAY LINE OF JOHN ANDERSON HIGHWAY (STATE ROAD 201) AND THE NORTH LINE OF SAID SECTION 38-12-31; THENCE SOUTH 71°47'17" WEST, A DISTANCE OF 100.00 FEET TO A POINT ON THE WEST RIGHT OF WAY LINE OF JOHN ANDERSON HIGHWAY (STATE ROAD 201), ALSO BEING THE POINT OF BEGINNING; THENCE ALONG SAID WEST RIGHT OF WAY LINE THE FOLLOWING THREE COURSES: SOUTH 18°10'26" EAST, A DISTANCE OF 3,184.36 FEET TO A POINT OF CURVATURE OF A NON-TANGENT CURVE CONCAVE NORTHEASTERLY HAVING A RADIUS OF 1,196.28 FEET, A CENTRAL ANGLE OF 22°09'26" AND A CHORD DISTANCE OF 459.74 FEET WHICH BEARS SOUTH 29°14'21" EAST; THENCE SOUTHEASTERLY ALONG THE ARC OF SAID CURVE A DISTANCE OF 462.62 FEET; THENCE SOUTH 40°21'41" EAST, A DISTANCE OF 776.28 FEET; THENCE DEPARTING SAID WEST RIGHT OF WAY LINE SOUTH 69°18'47" WEST, A DISTANCE OF 1,433.82 FEET, THENCE NORTH 20°41'22" WEST, A DISTANCE OF 995.98 FEET, THENCE NORTH 24°04'44" WEST, A DISTANCE OF 1,618.01 FEET; THENCE NORTH 86°17'06" WEST, A DISTANCE OF 2,604.28 FEET; THENCE NORTH 60°37'10" WEST, A DISTANCE OF 341.50 FEET; THENCE NORTH 43°23'02" WEST, A DISTANCE OF 2,172.87 FEET, THENCE NORTH 30°47'31" EAST, A DISTANCE OF 1,526.35 FEET; THENCE NORTH 45°31'15" EAST, A DISTANCE OF 902.38 FEET; THENCE NORTH 40°14'18" WEST, A DISTANCE OF 1,732.75 FEET; THENCE NORTH 06°10'40" WEST, A DISTANCE OF 189.68 FEET; THENCE NORTH 00°15'33" WEST, A DISTANCE OF 614.90 FEET; THENCE NORTH 88°32'16" EAST, A DISTANCE OF 257.93 FEET; THENCE NORTH 01°27'08" WEST, A DISTANCE OF 1,087.72 FEET TO A POINT ON THE SOUTH LINE OF STATE ROAD NO. 100; THENCE ALONG SAID SOUTH RIGHT OF WAY LINE SOUTH 89°29'03" EAST A DISTANCE OF 959.81 FEET; THENCE DEPARTING SAID SOUTH RIGHT OF WAY LINE SOUTH 00°30'57" WEST, A DISTANCE OF 210.00 FEET; THENCE SOUTH 89°29'03" EAST, A DISTANCE OF 210.00 FEET; THENCE SOUTH 00°30'57" WEST, A DISTANCE OF 389.92 FEET; THENCE SOUTH 89°28'38" EAST, A DISTANCE OF 822.42 FEET; THENCE SOUTH 00°06'48" EAST, A DISTANCE OF 1,704.61 FEET; THENCE NORTH 88°51'12" EAST, A DISTANCE OF 1,350.55 FEET; THENCE SOUTH 01°10'32" EAST, A DISTANCE OF 660.84 FEET; THENCE NORTH 88°37'17" EAST, A DISTANCE OF 158.75 FEET; THENCE SOUTH 18°14'40" EAST, A DISTANCE OF 330.09 FEET; THENCE NORTH 88°50'11" EAST, A DISTANCE OF 330.04 FEET TO A POINT ON THE WEST RIGHT OF WAY LINE OF JOHN ANDERSON HIGHWAY (STATE ROAD 201); THENCE ALONG SAID RIGHT OF WAY LINE SOUTH 18°15'00" EAST, A DISTANCE OF 1,788.60 FEET TO THE POINT OF BEGINNING.

**TOGETHER WITH:**

A PORTION OF SECTIONS 13, 14 AND 38, TOWNSHIP 12 SOUTH, RANGE 31 EAST, FLAGLER COUNTY, FLORIDA, BEING MORE PARTICULARLY DESCRIBED AS FOLLOWS:

BEGINNING AT THE INTERSECTION OF THE EAST RIGHT OF WAY LINE OF JOHN ANDERSON HIGHWAY (STATE ROAD 201) AND THE NORTH LINE OF SAID SECTION 38-12-31; THENCE ALONG SAID EAST RIGHT-OF-WAY LINE NORTH 18°15'00" WEST, A DISTANCE OF 2,087.53



FEET; THENCE DEPARTING SAID EAST RIGHT OF WAY LINE NORTH 88°47'52" EAST, A DISTANCE OF 710.35 FEET TO A POINT ON THE WEST LINE OF SECTION 13-12-31; THENCE ALONG SAID WEST SECTION LINE NORTH 01°13'40" WEST, A DISTANCE OF 661.23 FEET TO A POINT ON THE NORTH LINE OF SECTION 13-21-31; THENCE ALONG SAID NORTH SECTION LINE NORTH 88°36'18" EAST, A DISTANCE OF 1,890.40 FEET TO THE POINT ON THE WEST RIGHT OF WAY LINE OF FLORIDA INTRACOASTAL WATERWAY; THENCE ALONG SAID WEST RIGHT OF WAY LINE THE FOLLOWING TWO COURSES: SOUTH 13°59'25" EAST, A DISTANCE OF 2,750.14 FEET; THENCE SOUTH 21°17'55" EAST, A DISTANCE OF 1,265.83 FEET; THENCE DEPARTING SAID WEST RIGHT OF WAY LINE AND ALONG A WESTERLY LINE OF THE HISTORIC CHANNEL OF HAW LOVER CREEK, SOUTH 03°54'35" WEST, A DISTANCE OF 148.38 FEET; THENCE SOUTH 19°27'08" EAST, A DISTANCE OF 643.95 FEET; THENCE SOUTH 68°38'53" EAST, A DISTANCE OF 113.53 FEET TO A POINT ON THE AFORESAID INTRACOASTAL RIGHT OF WAY, THENCE SOUTH 21°17'55" EAST, A DISTANCE OF 647.80 FEET; THENCE DEPARTING SAID RIGHT OF WAY SOUTH 69°10'09" WEST, A DISTANCE OF 2,520.12 FEET TO A POINT ON THE EAST RIGHT OF WAY LINE OF JOHN ANDERSON HIGHWAY (STATE ROAD 201); THENCE ALONG SAID EAST RIGHT OF WAY LINE THE FOLLOWING THREE COURSES: NORTH 40°21'41" WEST, A DISTANCE OF 74.31 FEET TO A POINT OF CURVATURE OF A NON-TANGENT CURVE CONCAVE NORTHEASTERLY HAVING A RADIUS OF 1,095.28 FEET, A CENTRAL ANGLE OF 22°09'21" AND A CHORD DISTANCE OF 421.29 FEET WHICH BEARS NORTH 29°14'17" WEST; THENCE NORTHWESTERLY ALONG THE ARC OF SAID CURVE A DISTANCE OF 423.92 FEET; THENCE NORTH 18°10'26" WEST, A DISTANCE OF 3,184.44 FEET TO THE POINT OF BEGINNING.  
FORMERLY KNOWN AS GARDENS AT HAMMOCK BEACH, ACCORDING TO THE PLAT THEREOF, AS RECORDED IN PLAT BOOK 35, PAGES 80 THROUGH 100, PUBLIC RECORDS OF FLAGLER COUNTY, FLORIDA.

**LESS AND EXCEPT:** THE LAND CONTAINED IN THE QUIT CLAIM DEED TO EAST FLAGLER MOSQUITO CONTROL DISTRICT RECORDED IN OFFICIAL RECORDS BOOK 1620, PAGE 434, PUBLIC RECORDS OF FLAGLER COUNTY, FLORIDA. CONTAINING 0.89 ACRES, MORE OR LESS.

**LESS AND EXCEPT:** THE LAND CONTAINED IN THE SPECIAL WARRANTY DEED TO FLAGLER COUNTY RECORDED IN OFFICIAL RECORDS BOOK 1636, PAGE 1694, PUBLIC RECORDS OF FLAGLER COUNTY, FLORIDA. CONTAINING 81.32 ACRES, MORE OR LESS.

**LESS AND EXCEPT:** THE LAND CONTAINED IN THE SPECIAL WARRANTY DEED TO HIGHWAY 100 COMMERCIAL LLC RECORDED IN OFFICIAL RECORDS BOOK 1789, PAGE 750, PUBLIC RECORDS OF FLAGLER COUNTY, FLORIDA. CONTAINING 18.94 ACRES, MORE OR LESS.

**LESS AND EXCEPT:** TRACTS PL-2 AND PL-3, OF THE VACATED PLAT OF GARDENS AT HAMMOCK BEACH, ACCORDING TO THE PLAT THEREOF AS RECORDED IN PLAT BOOK 35, PAGES 80 THROUGH 100, PUBLIC RECORDS OF FLAGLER COUNTY, FLORIDA. CONTAINING A TOTAL OF 13.17 ACRES, MORE OR LESS.

**TOGETHER WITH:**

A PORTION OF TRACT "FD2", GARDENS AT HAMMOCK BEACH, AS RECORDED IN MAP BOOK 35, PAGES 80 THROUGH 100 OF THE PUBLIC RECORDS OF FLAGLER COUNTY, FLORIDA AND BEING MORE PARTICULARLY DESCRIBED AS FOLLOWS:

FOR A POINT OF BEGINNING COMMENCE AT THE NORTHWESTERLY CORNER OF SAID TRACT "FD2", SAID POINT ALSO BEING ON THE SOUTHERLY RIGHT OF WAY LINE OF STATE ROAD 100 (A 200 FOOT RIGHT OF WAY AS ESTABLISHED); THENCE SOUTH 89 DEGREES 29 MINUTES 03 SECONDS EAST, ALONG SAID SOUTHERLY RIGHT OF WAY LINE, A DISTANCE OF 382.15 FEET TO THE INTERSECTION WITH SOUTHWESTERLY RIGHT OF WAY LINE OF VILLA DRIVE WEST (A VARIABLE WIDTH PRIVATE RIGHT OF WAY AS ESTABLISHED), SAID POINT BEING THE POINT OF CURVATURE OF A CURVE CONCAVE SOUTHWESTERLY AND HAVING A RADIUS OF 35.00 FEET; THENCE ALONG SAID CURVE AND SAID SOUTHWESTERLY RIGHT OF WAY LINE AN ARC DISTANCE OF 51.49 FEET TO THE POINT OF TANGENCY OF SAID CURVE, SAID CURVE BEING SUBTENDE BY A CHORD BEARING OF SOUTH 41 DEGREES 37 MINUTES 50 SECONDS EAST, AND A CHORD DISTANCE OF 46.97 FEET; THENCE SOUTH 00 DEGREES 30 MINUTES 47 SECONDS WEST, A DISTANCE OF 29.81 FEET TO THE POINT OF CURVATURE OF A CURVE CONCAVE NORTHEASTERLY AND HAVING A RADIUS OF 470.00 FEET; THENCE ALONG SAID CURVE AN ARC DISTANCE OF 578.46 FEET TO THE POINT OF TANGENCY OF SAID CURVE, SAID CURVE BEING SUBTENDE BY A CHORD BEARING OF SOUTH 34 DEGREES 44 MINUTES 45 SECONDS EAST, AND A CHORD DISTANCE OF 542.64 FEET; THENCE SOUTH 70 DEGREES 00 MINUTES 17 SECONDS EAST, A DISTANCE OF 190.75 FEET TO THE POINT OF CURVATURE OF A CURVE CONCAVE SOUTHWESTERLY AND HAVING A RADIUS OF 360.00 FEET; THENCE ALONG SAID CURVE AN ARC DISTANCE OF 364.42 FEET TO THE POINT OF TANGENCY OF SAID CURVE, SAID CURVE BEING SUBTENDE BY A CHORD BEARING OF SOUTH 41 DEGREES 00 MINUTES 17 SECONDS EAST, AND A CHORD DISTANCE OF 349.06 FEET; THENCE SOUTH 12 DEGREES 00 MINUTES 17 SECONDS EAST, A DISTANCE OF 170.79 FEET TO THE POINT OF CURVATURE OF A CURVE CONCAVE WESTERLY AND HAVING A RADIUS OF 260.00 FEET; THENCE ALONG SAID CURVE AN ARC DISTANCE OF 48.62 FEET, SAID CURVE BEING SUBTENDE BY A CHORD BEARING OF SOUTH 06 DEGREES 3B MINUTES 50 SECONDS EAST AND A CHORD DISTANCE OF 48.55 FEET; THENCE SOUTH 88 DEGREES 37 MINUTES 36 SECONDS WEST DEPARTING THE AFOREMENTIONED SOUTHWESTERLY RIGHT OF LINE OF VILLA DRIVE WEST, A DISTANCE OF 471.38 FEET; THENCE SOUTH 88 DEGREES 28 MINUTES 30 SECONDS WEST, A DISTANCE OF 589.08 FEET; THENCE NORTH 33 DEGREES 37 MINUTES 07 SECONDS WEST, A DISTANCE OF 50.65 FEET; THENCE NORTH 38 DEGREES 07 MINUTES 37 SECONDS WEST, A DISTANCE OF 95.67 FEET TO A POINT ON A WESTERLY LINE OF THE AFOREMENTIONED TRACT "FD2, GARDENS AT HAMMOCK BEACH"; THENCE NORTH 01 DEGREES 27 MINUTES 08 SECONDS WEST, A DISTANCE OF 968.01 FEET TO THE POINT OF BEGINNING.

**ALSO, TOGETHER WITH:** A PARCEL OF LAND IN THE SOUTH 1/2 OF SECTION 11, TOWNSHIP 12 SOUTH, RANGE 31 EAST, FLAGLER COUNTY, FLORIDA, MORE PARTICULARLY DESCRIBED AS FOLLOWS:

COMMENCE AT THE SOUTHWEST CORNER OF GOVERNMENT SECTION 11, TOWNSHIP 12 SOUTH, RANGE 31 EAST AS MONUMENTED BY A 4" X 4" CONCRETE MONUMENT INSCRIBED WITH A "T"; THENCE ALONG THE SOUTHERLY LINE OF SAID SECTION 11 NORTH 88°51'19" EAST A DISTANCE OF 2,591.75 FEET TO THE POINT OF BEGINNING; THENCE NORTH 00°06'41" EAST A DISTANCE OF 1,287.36 FEET; THENCE NORTH 88°28'36" EAST A DISTANCE OF 680.27 FEET; THENCE SOUTH 01°24'50" EAST, A DISTANCE OF 345.10 FEET; THENCE SOUTH 88°36'24" WEST, A DISTANCE OF 150.00 FEET; THENCE SOUTH 01°28'15" EAST, A DISTANCE OF 300.30 FEET; THENCE NORTH 88°36'24" EAST, A DISTANCE OF 150.00 FEET; THENCE SOUTH 01°08'43" EAST, A DISTANCE OF 24.77 FEET; THENCE NORTH 88°54'22" EAST, A DISTANCE OF 749.54 FEET TO A POINT ON THE WESTERLY RIGHT OF WAY LINE OF STATE ROAD 201, (ALSO KNOWN AS JOHN ANDERSON HIGHWAY);

THENCE ALONG SAID WESTERLY RIGHT OF WAY LINE, SOUTH 18°11'55" EAST, A DISTANCE OF 401.46 FEET; THENCE DEPARTING SAID RIGHT OF WAY LINE, SOUTH 77°14'08" WEST, A DISTANCE OF 99.57 FEET; THENCE SOUTH 01°16'02" EAST, A DISTANCE OF 216.94 FEET; THENCE SOUTH 88°50'35" WEST, A DISTANCE OF 126.47 FEET TO A POINT ON THE SOUTHERLY LINE OF AFORESAID SECTION 11; THENCE ALONG SAID SOUTHERLY LINE SOUTH 88°51'19" WEST, A DISTANCE OF 1,350.55 FEET TO THE POINT OF BEGINNING.

**ALSO, TOGETHER WITH:** A PARCEL OF LAND IN SECTION 12, TOWNSHIP 12 SOUTH, RANGE 31 EAST, FLAGLER COUNTY, FLORIDA, MORE PARTICULARLY DESCRIBED AS FOLLOWS:

BEGIN AT THE SOUTHWEST CORNER OF SAID GOVERNMENT SECTION 12, THENCE DEPARTING SAID SOUTHERLY LINE NORTH 01°30'23" WEST A DISTANCE OF 1,203.23 FEET ALONG THE WESTERLY LINE OF SAID SECTION 12; THENCE NORTH 88°52'15" EAST, A DISTANCE OF 649.96 FEET; THENCE SOUTH 19°00'52" EAST, A DISTANCE OF 1,265.64 FEET; THENCE SOUTH 88°56'30" WEST, ALONG SAID SECTION LINE, A DISTANCE OF 1,030.73 FEET TO THE POINT OF BEGINNING.

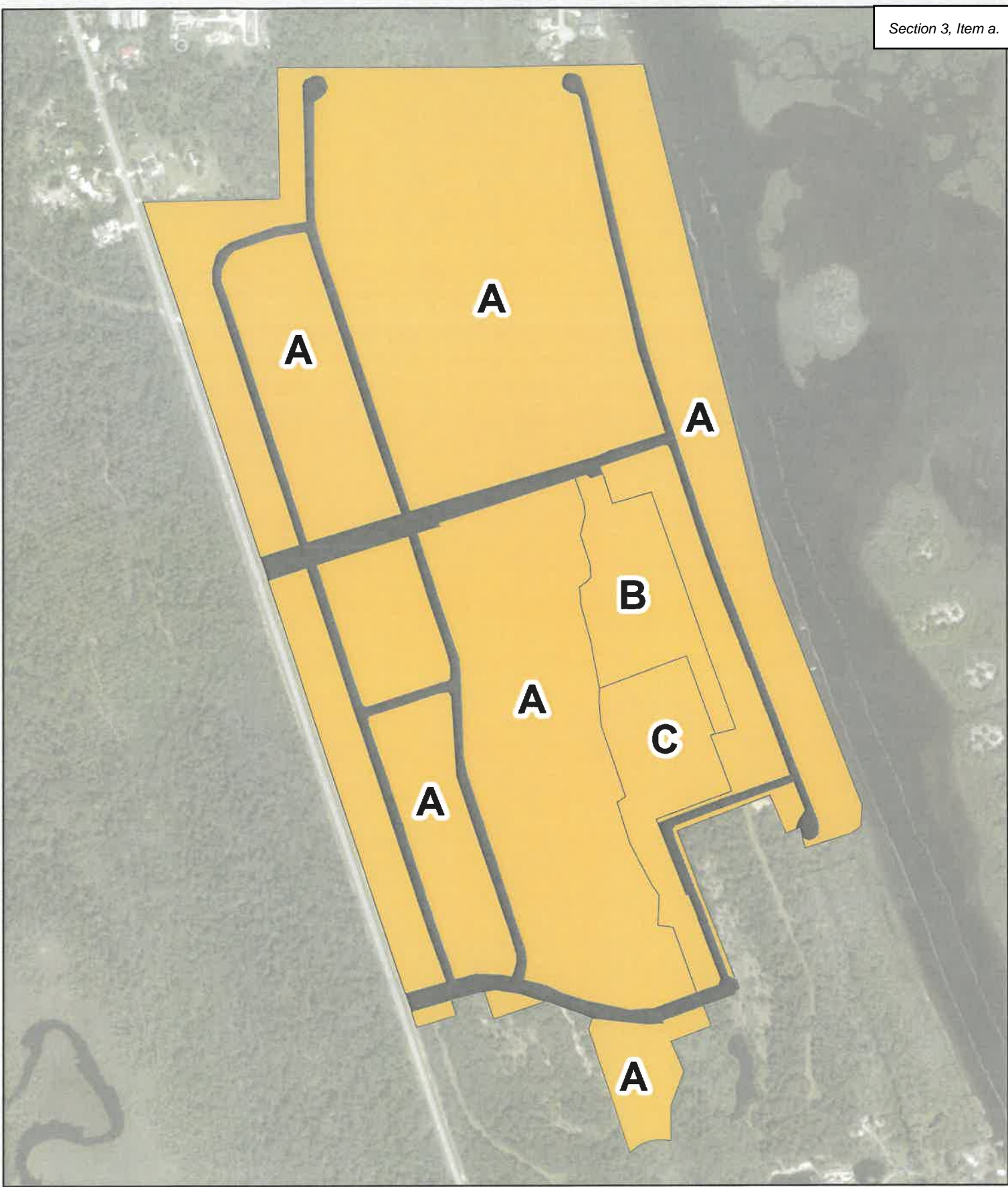

Exhibit "B"  
Approved Properties  
Veranda Bay  
Flagler County, Florida

Date: 6-20-24



### Approved Properties Exhibit "B"

#### Phase 1A

A PORTION OF SECTIONS 13,14 AND 38, TOWNSHIP 12 SOUTH, RANGE 31 EAST, FLAGLER COUNTY, FLORIDA, AND BEING MORE PARTICULARLY DESCRIBED AS FOLLOWS: FOR A POINT OF BEGINNING, COMMENCE AT THE INTERSECTION OF THE EAST RIGHT OF WAY LINE OF JOHN ANDERSON HIGHWAY (COUNTY ROAD 201) AND THE NORTH LINE OF SAID SECTION 38; THENCE NORTH 18°15'20" WEST ALONG SAID EAST RIGHT OF WAY LINE, A DISTANCE OF 228.50 FEET; THENCE NORTH 71°44'40" EAST, DEPARTING FROM SAID RIGHT OF WAY LINE, A DISTANCE OF 225.00 FEET; THENCE SOUTH 18°15'20" EAST, A DISTANCE OF 85.01 FEET; THENCE NORTH 71°54'58" EAST, A DISTANCE OF 50.00 FEET TO A POINT ON CURVE OF A CURVE CONCAVE TO THE NORTHEAST AND HAVING A RADIUS OF 25.00 FEET AND A CENTRAL ANGLE OF 89°54'30"; THENCE SOUTHEASTERLY ALONG SAID CURVE AN ARC DISTANCE OF 39.23 FEET AND SUBTENDED BY A CHORD BEARING OF SOUTH 63°12'59" EAST AND A CHORD DISTANCE OF 35.33 FEET TO THE POINT OF TANGENCY OF SAID CURVE; THENCE NORTH 71°49'46" EAST, A DISTANCE OF 445.00 FEET TO THE POINT OF CURVE OF A CURVE CONCAVE THE NORTHWEST AND HAVING A RADIUS OF 25.00 FEET AND A CENTRAL ANGLE OF 90°04'07"; THENCE NORTHEASTERLY ALONG SAID CURVE AN ARC DISTANCE OF 39.30 FEET AND SUBTENDED BY A CHORD BEARING OF NORTH 26°47'43" EAST AND A CHORD DISTANCE OF 35.38 FEET TO A POINT ON SAID CURVE; THENCE NORTH 71°44'40" EAST, A DISTANCE OF 50.00 FEET; THENCE SOUTH 18°15'20" EAST, A DISTANCE OF 20.14 FEET TO THE POINT OF CURVE OF A CURVE CONCAVE TO THE NORTHEAST AND HAVING A RADIUS OF 25.00 FEET AND A CENTRAL ANGLE OF 11°27'07"; THENCE SOUTHEASTERLY ALONG SAID CURVE AN ARC DISTANCE OF 5.00 FEET AND SUBTENDED BY A CHORD BEARING OF SOUTH 23°58'54" EAST AND A CHORD DISTANCE OF 4.99 FEET TO A POINT ON SAID CURVE; THENCE NORTH 71°49'46" EAST, A DISTANCE OF 139.50 FEET; THENCE NORTH 18°15'20" WEST, A DISTANCE OF 260.49 FEET; THENCE SOUTH 71°44'40" WEST, A DISTANCE OF 140.00 FEET; THENCE NORTH 18°15'20" WEST, A DISTANCE OF 20.00 FEET; THENCE NORTH 71°44'40" EAST, A DISTANCE OF 140.00 FEET; THENCE NORTH 18°15'20" WEST, A DISTANCE OF 960.00 FEET; THENCE SOUTH 71°44'40" WEST, A DISTANCE OF 140.00 FEET; THENCE NORTH 18°15'20" WEST, A DISTANCE OF 20.00 FEET; THENCE NORTH 71°44'40" EAST, A DISTANCE OF 140.00 FEET; THENCE NORTH 18°15'20" WEST, A DISTANCE OF 244.38 FEET; THENCE SOUTH 78°03'28" WEST, A DISTANCE OF 137.96 FEET TO A POINT ON CURVE OF A CURVE CONCAVE TO THE EAST AND HAVING A RADIUS OF 475.00 FEET AND A CENTRAL ANGLE OF 10°47'20"; THENCE NORTHEASTERLY ALONG SAID CURVE AN ARC DISTANCE OF 89.44 FEET AND BEING SUBTENDED BY A CHORD BEARING OF NORTH 06°32'52" WEST; AND CHORD DISTANCE OF 89.31 FEET TO A POINT ON SAID CURVE; THENCE NORTH 86°59'44" EAST, A DISTANCE OF 140.07 FEET; THENCE NORTH 01°09'12" WEST, A DISTANCE OF 568.36 FEET; THENCE NORTH 68°50'48" EAST, A DISTANCE OF 63.62 FEET; THENCE NORTH 01°07'10" WEST, A DISTANCE OF 161.55 FEET; THENCE NORTH 88°54'24" EAST, A DISTANCE OF 176.36 FEET; THENCE NORTH 11°52'10" EAST, A DISTANCE OF 25.29 FEET; THENCE NORTH 13°13'05" EAST, A DISTANCE OF 0.37 FEET; TO THE INTERSECTION WITH THE NORTH LINE OF SAID SECTION 13 AND SAID LINE ALSO BEING THE NORTHERLY LINE OF THOSE LANDS AS DESCRIBED IN OFFICIAL RECORDS BOOK 2281 PAGE 1643 AND RECORDED IN THE PUBLIC RECORDS OF SAID COUNTY; THENCE NORTH 88°54'24" EAST, ALONG SAID NORTHERLY LINE, A DISTANCE OF 1304.54 FEET TO THE POINT ON THE WEST RIGHT OF WAY LINE OF FLORIDA INTRACOASTAL WATERWAY; THENCE ALONG SAID WEST RIGHT OF WAY LINE SOUTH 13°58'25" EAST, A DISTANCE OF 1950.65 FEET; THENCE SOUTH 71°49'48" WEST, DEPARTING FROM SAID RIGHT OF WAY LINE, A DISTANCE OF 334.12 FEET; THENCE NORTH 18°10'12" WEST, A DISTANCE OF 3.02 FEET TO THE POINT OF CURVE OF A CURVE CONCAVE TO THE SOUTHWEST AND HAVING A RADIUS OF 25.00 FEET AND A CENTRAL ANGLE OF 90°00'02"; THENCE NORTHWESTERLY ALONG SAID CURVE AN ARC DISTANCE OF 39.27 FEET AND SUBTENDED BY A CHORD BEARING OF NORTH 63°10'13" WEST AND A CHORD DISTANCE OF 35.36 FEET TO THE POINT OF TANGENCY OF SAID CURVE; THENCE SOUTH 71°49'46" WEST, A DISTANCE OF 149.59 FEET; THENCE SOUTH 18°10'14" EAST, A DISTANCE OF 50.00 FEET; THENCE SOUTH 71°49'46" WEST, A DISTANCE OF 50.00 FEET; THENCE NORTH 8°10'14" WEST, A DISTANCE OF 50.00 FEET; THENCE SOUTH 71°49'46" WEST, A DISTANCE OF 134.59 FEET TO THE POINT OF CURVE OF A CURVE CONCAVE TO THE SOUTHEAST AND HAVING A RADIUS OF 25.00 FEET AND A CENTRAL ANGLE OF 90°00'00"; THENCE SOUTHWESTERLY ALONG SAID CURVE AN ARC DISTANCE OF 38.27 FEET AND BEING SUBTENDED BY A CHORD BEARING OF SOUTH 26°43'46" WEST AND A CHORD DISTANCE OF 35.36 FEET TO A POINT ON SAID CURVE; THENCE SOUTH 71°49'46" WEST, A DISTANCE OF 70.00 FEET TO A POINT ON A CURVE OF A CURVE CONCAVE TO THE SOUTHWEST AND HAVING A RADIUS OF 5.00 FEET AND A CENTRAL ANGLE OF 90°00'00"; THENCE NORTHWESTERLY ALONG SAID CURVE AN ARC DISTANCE OF 7.85 FEET AND SUBTENDED BY A CHORD BEARING OF NORTH 63°10'14" WEST AND A CHORD DISTANCE OF 7.07 FEET TO THE POINT OF TANGENCY OF SAID CURVE; THENCE SOUTH 71°49'46" WEST, A DISTANCE OF 557.17 FEET; THENCE SOUTH 18°10'14" EAST, A DISTANCE OF 40.00 FEET; THENCE SOUTH 71°49'46" WEST, A DISTANCE OF 25.00 FEET; THENCE NORTH 18°10'14" WEST, A DISTANCE 40.00 FEET; THENCE SOUTH 71°49'46" WEST, A DISTANCE OF 337.90 FEET TO A POINT ON A CURVE OF A CURVE CONCAVE TO THE SOUTHEAST AND HAVING A RADIUS OF 25.00 FEET AND A CENTRAL ANGLE OF 11°32'14"; THENCE SOUTHWESTERLY ALONG SAID CURVE AN ARC DISTANCE OF 5.03 FEET AND SUBTENDED BY A CHORD BEARING OF SOUTH 12°24'08" EAST AND A CHORD DISTANCE OF 5.03 FEET TO THE POINT OF TANGENCY OF SAID CURVE; THENCE SOUTH 18°10'14" EAST, A DISTANCE OF 20.01 FEET; THENCE SOUTH 71°49'46" WEST, A DISTANCE OF 50.00 FEET; THENCE SOUTH 18°10'14" EAST, A DISTANCE OF 325.00 FEET; THENCE SOUTH 71°49'46" WEST, A DISTANCE OF 770.00 FEET TO THE INTERSECTION WITH THE AFOREMENTIONED WEST RIGHT OF WAY LINE OF JOHN ANDERSON HIGHWAY; THENCE NORTH 18°10'14" WEST, ALONG SAID RIGHT OF WAY LINE, A DISTANCE OF 331.23 FEET TO THE POINT OF BEGINNING, CONTAINING 90.49 ACRES, MORE OR LESS.

Together with

Phase 1B

A PORTION OF SECTION 13, TOWNSHIP 12 SOUTH, RANGE 31 EAST, FLAGLER COUNTY, FLORIDA, AND BEING MORE PARTICULARLY DESCRIBED AS FOLLOWS: COMMENCE AT THE INTERSECTION OF THE EAST RIGHT OF WAY LINE OF JOHN ANDERSON HIGHWAY (COUNTY ROAD 201 AND 100 FOOT RIGHT OF WAY) AND THE SOUTH LINE OF SECTION 14 OF SAID TOWNSHIP 12 SOUTH, RANGE 31 EAST AND SAID POINT ALSO LIES ON THE WESTERLY LINE TRACT 1A-1 OF VERANDA BAY PHASE 1A AS RECORDED IN PLAT BOOK 40, PAGES 59 THROUGH 64 OF THE PUBLIC RECORDS OF SAID COUNTY; THENCE NORTH 18°15'20" WEST ALONG SAID WESTERLY LINE OF VERANDA BAY PHASE 1A, ALSO ALONG SAID EAST RIGHT OF WAY LINE, A DISTANCE OF 228.50 FEET TO THE NORTHWEST CORNER OF TRACT 1A-2 OF SAID VERANDA BAY PHASE 1A ; THENCE NORTH 71°44'40" EAST, DEPARTING FROM SAID RIGHT OF WAY LINE AND ALONG THE NORTHERLY LINE OF SAID TRACT 1A-2, A DISTANCE OF 225.00 FEET TO THE NORTHEAST CORNER OF SAID TRACT 1A-2; THENCE SOUTH 18°15'20" EAST ALONG THE EASTERLY LINE OF SAID TRACT 1A-2, A DISTANCE OF 85.01 FEET; THENCE ALONG A NORTHERLY LINE OF SAID TRACT 1A-1 THE FOLLOWING THREE COURSES: NORTH 71°54'56" EAST, A DISTANCE OF 50.00 FEET TO A POINT ON A CURVE OF A CURVE CONCAVE TO THE NORTHEAST AND HAVING A RADIUS OF 25.00 FEET AND A CENTRAL ANGLE OF 89°54'30"; THENCE SOUTHEASTERLY ALONG SAID CURVE AN ARC DISTANCE OF 39.23 FEET AND SUBTENDED BY A CHORD BEARING OF SOUTH 63°12'58" EAST AND A CHORD DISTANCE OF 35.33 FEET TO THE POINT OF TANGENCY OF SAID CURVE; THENCE NORTH 71°49'46" EAST, A DISTANCE OF 330.04 FEET TO THE POINT OF BEGINNING; THENCE DEPARTING FROM SAID NORTHERLY LINE OF TRACT 1A-1, NORTH 18°15'20" WEST, A DISTANCE OF 259.99 FEET; THENCE NORTH 71°44'40" EAST, A DISTANCE OF 140.00 FEET; THENCE NORTH 18°15'20" WEST, A DISTANCE OF 20.00 FEET; THENCE SOUTH 71°44'40" WEST, A DISTANCE OF 140.00 FEET; THENCE NORTH 18°15'20" WEST, A DISTANCE OF 960.00 FEET; THENCE NORTH 71°44'40" EAST, A DISTANCE OF 140.00 FEET; THENCE NORTH 18°15'20" WEST, A DISTANCE 20.00 FEET; THENCE SOUTH 71°44'40" WEST, A DISTANCE OF 140.00 FEET; THENCE NORTH 18°15'20" WEST, A DISTANCE OF 309.49 FEET; THENCE NORTH 11°30'49" WEST, A DISTANCE OF 50.00 FEET TO A POINT ON A CURVE OF A CURVE CONCAVE SOUTHERLY AND HAVING A RADIUS OF 325.00 FEET AND A CENTRAL ANGLE OF 02°07'45"; THENCE EASTERLY ALONG SAID CURVE AN ARC DISTANCE OF 12.08 FEET AND SUBTENDED BY A CHORD BEARING OF NORTH 79°33'04" EAST AND A CHORD DISTANCE OF 12.08 FEET TO A POINT ON SAID CURVE; THENCE NORTH 06°55'48" WEST, A DISTANCE OF 122.14 FEET; THENCE NORTH 01°09'12" WEST, ALONG THE EASTERLY LINE AND ITS SOUTHERLY PROLONGATION OF SAID LANDS AS DESCRIBED IN OFFICIAL RECORDS BOOK 927, PAGE 1938 OF THE PUBLIC RECORDS OF SAID COUNTY AND ALSO ALONG THE EASTERLY LINE OF THOSE LANDS AS DESCRIBED IN OFFICIAL RECORDS BOOK 801, PAGE 1414 OF SAID PUBLIC RECORDS, A DISTANCE OF 685.12 FEET TO THE NORTHEAST CORNER OF SAID LANDS AND SAID POINT ALSO BEING THE NORTHWEST CORNER OF THOSE LANDS AS DESCRIBED IN OFFICIAL RECORDS BOOK 2281, PAGE 1643 OF SAID PUBLIC RECORDS AND SAID POINT ALSO BEING ON THE NORTH LINE OF SAID SECTION 13; THENCE NORTH 88°54'24" EAST, ALONG SAID NORTHERLY LINE OF SAID SECTION 13 AND ALSO ALONG THE NORTHERLY LINE OF SAID LANDS AS DESCRIBED IN OFFICIAL RECORDS BOOK 2281, PAGE 1643, A DISTANCE OF 585.86 FEET TO THE NORTHWEST CORNER OF TRACT 1A-5 OF SAID VERANDA BAY PHASE 1A; THENCE ALONG THE WESTERLY LINE OF SAID TRACT 1A-5 THE FOLLOWING TWO COURSES: SOUTH 13°13'08" WEST, ALSO DEPARTING FROM SAID SECTION 13, A DISTANCE OF 0.37 FEET; THENCE SOUTH 11°52'10" WEST, A DISTANCE OF 25.29 FEET TO THE NORTHEAST CORNER OF TRACT 1A-4 OF SAID VERANDA BAY PHASE 1A; THENCE ALONG THE WESTERLY LINES OF SAID TRACT 1A-4 THE FOLLOWING TWELVE COURSES: THENCE SOUTH 88°54'24" WEST, A DISTANCE OF 176.36 FEET; THENCE SOUTH 01°07'10" EAST, A DISTANCE OF 161.55 FEET; THENCE SOUTH 88°50'48" WEST, A DISTANCE OF 63.62 FEET; THENCE SOUTH 01°09'12" EAST, A DISTANCE OF 568.36 FEET; THENCE SOUTH 86°59'44" WEST, A DISTANCE OF 140.07 FEET TO A POINT ON A CURVE OF A CURVE CONCAVE TO THE EAST AND HAVING A RADIUS OF 475.00 FEET AND HAVING A CENTRAL ANGLE OF 10°47'20"; THENCE SOUTHWESTERLY ALONG SAID CURVE AN ARC DISTANCE OF 89.44 FEET AND SUBTENDED BY A CHORD BEARING OF SOUTH 06°32'52" EAST AND A CHORD DISTANCE OF 89.31 FEET TO A POINT ON SAID CURVE; THENCE NORTH 78°03'28" EAST, A DISTANCE OF 137.95 FEET; THENCE SOUTH 18°15'20" EAST, A DISTANCE OF 244.38 FEET; THENCE SOUTH 71°44'40" WEST, A DISTANCE OF 140.00 FEET; THENCE SOUTH 18°15'20" EAST, A DISTANCE OF 20.00 FEET; THENCE NORTH 71°44'40" EAST, A DISTANCE OF 140.00 FEET; THENCE SOUTH 18°15'20" EAST, A DISTANCE OF 960.00 FEET; THENCE SOUTH 71°44'40" WEST, A DISTANCE OF 140.00 FEET; THENCE SOUTH 18°15'20" EAST, A DISTANCE OF 20.00 FEET; THENCE NORTH 71°44'40" EAST, A DISTANCE OF 140.00 FEET; THENCE SOUTH 18°15'20" EAST, A DISTANCE OF 260.48 FEET TO SOUTHWEST CORNER OF SAID TRACT 1A-4; THENCE SOUTH 71°49'46" WEST, ALONG THE NORTHERLY LINE OF TRACT 1A-11 OF SAID VERANDA BAY PHASE 1A , A DISTANCE OF 139.50 FEET TO THE NORTHWEST CORNER OF SAID TRACT 1A-11 AND SAID POINT ALSO IS A POINT ON A CURVE OF A CURVE CONCAVE TO THE EAST AND HAVING A RADIUS OF 25.00 FEET AND A CENTRAL ANGLE OF 11°26'00"; THENCE NORTHERLY ALONG SAID CURVE AND ALONG THE NORTHERLY LINE OF SAID TRACT 1A-11, AN ARC DISTANCE OF 4.99 FEET AND SUBTENDED BY A CHORD BEARING OF NORTH 23°59'27" WEST AND A CHORD DISTANCE OF 4.98 FEET TO THE POINT OF TANGENCY OF SAID CURVE; THENCE CONTINUING ALONG SAID NORTHERLY LINES THE FOLLOWING FOUR COURSES: NORTH 18°15'20" WEST, A DISTANCE OF 20.15 FEET; THENCE SOUTH 71°44'40" WEST, A DISTANCE OF 50.00 FEET TO A POINT ON A CURVE OF A CURVE CONCAVE TO THE NORTHWEST AND HAVING A RADIUS OF 25.00 FEET AND HAVING A CENTRAL ANGLE OF 90°04'06"; THENCE SOUTHWESTERLY ALONG SAID CURVE AN ARC DISTANCE OF 39.30 FEET AND BEING SUBTENDED BY A CHORD BEARING OF SOUTH 26°47'43" WEST AND A CHORD DISTANCE OF 35.38 FEET TO THE POINT OF TANGENCY OF SAID CURVE; THENCE SOUTH 71°49'46" WEST, A DISTANCE OF 114.96 FEET TO THE POINT OF BEGINNING. CONTAINING 18.02 ACRES, MORE OR LESS.

Together with

Phase 1C

A PORTION OF SECTIONS 13 AND 14, TOWNSHIP 12 SOUTH, RANGE 31 EAST, FLAGLER COUNTY, FLORIDA, AND BEING MORE PARTICULARLY DESCRIBED AS FOLLOWS: COMMENCE AT THE INTERSECTION OF THE EAST RIGHT OF WAY LINE OF JOHN ANDERSON HIGHWAY (COUNTY ROAD 201 AND 100 FOOT RIGHT OF WAY) AND THE SOUTH LINE OF SECTION 14 OF SAID TOWNSHIP 12 SOUTH, RANGE 31 EAST AND SAID POINT ALSO LIES ON THE WESTERLY LINE TRACT 1A-1 OF VERANDA BAY PHASE 1A AS RECORDED IN PLAT BOOK 40, PAGES 59 THROUGH 64 OF THE PUBLIC RECORDS OF SAID COUNTY; THENCE NORTH 18°15'20" WEST ALONG SAID WESTERLY LINE OF VERANDA BAY PHASE 1A-1, ALSO ALONG SAID EAST RIGHT OF WAY LINE, A DISTANCE OF 228.50 FEET TO THE NORTHWEST CORNER OF TRACT 1A-2 OF SAID VERANDA BAY PHASE 1A AND ALSO TO THE POINT OF BEGINNING; THENCE CONTINUE NORTH 18°15'20" WEST ALONG SAID EAST RIGHT OF WAY LINE, A DISTANCE OF 1858.74 FEET TO THE SOUTHWEST CORNER OF THOSE LANDS AS DESCRIBED IN OFFICIAL RECORDS BOOK 927, PAGE 1938 OF THE PUBLIC RECORDS OF SAID COUNTY AND SAID POINT ALSO BEING A NORTHWEST CORNER OF THOSE LANDS IN OFFICIAL RECORDS BOOK 2281, PAGE 1643 OF SAID PUBLIC RECORDS; THENCE NORTH 88°47'24" EAST, ALONG THE SOUTHERLY LINE OF SAID LANDS AS DESCRIBED IN OFFICIAL RECORDS BOOK 927, PAGE 1938 AND ALSO ALONG A NORTHERLY LINE OF SAID LANDS DESCRIBED IN OFFICIAL RECORDS BOOK 2281, PAGE 1643, A DISTANCE OF 710.39 FEET TO THE SOUTHEAST CORNER OF SAID LANDS DESCRIBED IN OFFICIAL RECORDS BOOK 927, PAGE 1938; THENCE SOUTH 01°09'12" EAST, A DISTANCE OF 25.00 FEET; THENCE SOUTH 06°55'48" EAST, A DISTANCE OF 122.14 FEET TO A POINT ON A CURVE OF A CURVE CONCAVE SOUTHERLY AND HAVING A RADIUS OF 325.00 FEET AND A CENTRAL ANGLE OF 02°07'45"; THENCE WESTERLY ALONG SAID CURVE AN ARC DISTANCE OF 12.08 FEET AND SUBTENDED BY A CHORD BEARING OF SOUTH 79°33'04" WEST AND A CHORD DISTANCE OF 12.08 FEET TO A POINT ON SAID CURVE; THENCE SOUTH 11°30'49" EAST, A DISTANCE OF 50.00 FEET; THENCE SOUTH 18°15'20" EAST, A DISTANCE OF 20.00 FEET; THENCE NORTH 71°44'40" EAST, A DISTANCE OF 140.00 FEET; THENCE SOUTH 18°15'20" EAST, A DISTANCE OF 20.00 FEET; THENCE SOUTH 71°44'40" WEST, A DISTANCE OF 140.00 FEET; THENCE NORTH 18°15'20" WEST, A DISTANCE OF 309.49 FEET; THENCE NORTH 11°30'49" WEST, A DISTANCE OF 50.00 FEET TO A POINT ON A CURVE OF A CURVE CONCAVE SOUTHERLY AND HAVING A RADIUS OF 325.00 FEET AND A CENTRAL ANGLE OF 02°07'45"; THENCE EASTERLY ALONG SAID CURVE AN ARC DISTANCE OF 12.08 FEET AND SUBTENDED BY A CHORD BEARING OF NORTH 79°33'04" WEST AND A CHORD DISTANCE OF 12.08 FEET TO A POINT ON SAID CURVE; THENCE NORTH 06°55'48" WEST, A DISTANCE OF 122.14 FEET; THENCE NORTH 01°09'12" WEST, ALONG THE EASTERLY LINE AND ITS SOUTHERLY PROLONGATION OF SAID LANDS AS DESCRIBED IN OFFICIAL RECORDS BOOK 927, PAGE 1938 OF THE PUBLIC RECORDS OF SAID COUNTY AND ALSO ALONG THE EASTERLY LINE OF THOSE LANDS AS DESCRIBED IN OFFICIAL RECORDS BOOK 801, PAGE 1414 OF SAID PUBLIC RECORDS, A DISTANCE OF 685.12 FEET TO THE NORTHEAST CORNER OF SAID LANDS AND SAID POINT ALSO BEING THE NORTHWEST CORNER OF THOSE LANDS AS DESCRIBED IN OFFICIAL RECORDS BOOK 2281, PAGE 1643 OF SAID PUBLIC RECORDS AND SAID POINT ALSO BEING ON THE NORTH LINE OF SAID SECTION 13; THENCE NORTH 88°54'24" EAST, ALONG SAID NORTHERLY LINE OF SAID SECTION 13 AND ALSO ALONG THE NORTHERLY LINE OF SAID LANDS AS DESCRIBED IN OFFICIAL RECORDS BOOK 2281, PAGE 1643, A DISTANCE OF 585.86 FEET TO THE NORTHWEST CORNER OF TRACT 1A-5 OF SAID VERANDA BAY PHASE 1A; THENCE ALONG THE WESTERLY LINE OF SAID TRACT 1A-5 THE FOLLOWING TWO COURSES: SOUTH 13°13'08" WEST, ALSO DEPARTING FROM SAID SECTION 13, A DISTANCE OF 0.37 FEET; THENCE SOUTH 11°52'10" WEST, A DISTANCE OF 25.29 FEET TO THE NORTHEAST CORNER OF TRACT 1A-4 OF SAID VERANDA BAY PHASE 1A; THENCE ALONG THE WESTERLY LINES OF SAID TRACT 1A-4 THE FOLLOWING TWELVE COURSES: THENCE SOUTH 88°54'24" WEST, A DISTANCE OF 176.36 FEET; THENCE SOUTH 01°07'10" EAST, A DISTANCE OF 161.55 FEET; THENCE SOUTH 88°50'48" WEST, A DISTANCE OF 63.62 FEET; THENCE SOUTH 01°09'12" EAST, A DISTANCE OF 568.36 FEET; THENCE SOUTH 86°59'44" WEST, A DISTANCE OF 140.07 FEET TO A POINT ON A CURVE OF A CURVE CONCAVE TO THE EAST AND HAVING A RADIUS OF 475.00 FEET AND HAVING A CENTRAL ANGLE OF 10°47'20"; THENCE SOUTHWESTERLY ALONG SAID CURVE AN ARC DISTANCE OF 89.44 FEET AND SUBTENDED BY A CHORD BEARING OF SOUTH 06°32'52" EAST AND A CHORD DISTANCE OF 89.31 FEET TO A POINT ON SAID CURVE; THENCE NORTH 78°03'28" EAST, A DISTANCE OF 137.95 FEET; THENCE SOUTH 18°15'20" EAST, A DISTANCE OF 244.38 FEET; THENCE SOUTH 71°44'40" WEST, A DISTANCE OF 140.00 FEET; THENCE SOUTH 18°15'20" EAST, A DISTANCE OF 20.00 FEET; THENCE NORTH 71°44'40" EAST, A DISTANCE OF 140.00 FEET; THENCE SOUTH 18°15'20" EAST, A DISTANCE OF 960.00 FEET; THENCE SOUTH 71°44'40" WEST, A DISTANCE OF 140.00 FEET; THENCE SOUTH 18°15'20" EAST, A DISTANCE OF 20.00 FEET; THENCE NORTH 71°44'40" EAST, A DISTANCE OF 140.00 FEET; THENCE SOUTH 18°15'20" EAST, A DISTANCE OF 260.48 FEET TO SOUTHWEST CORNER OF SAID TRACT 1A-4; THENCE SOUTH 71°49'46" WEST, ALONG THE NORTHERLY LINE OF TRACT 1A-11 OF SAID VERANDA BAY PHASE 1A , A DISTANCE OF 139.50 FEET TO THE NORTHWEST CORNER OF SAID TRACT 1A-11 AND SAID POINT ALSO IS A POINT ON A CURVE OF A CURVE CONCAVE TO THE EAST AND HAVING A RADIUS OF 25.00 FEET AND A CENTRAL ANGLE OF 11°26'00"; THENCE NORTHERLY ALONG SAID CURVE AND ALONG THE NORTHERLY LINE OF SAID TRACT 1A-11, AN ARC DISTANCE OF 4.99 FEET AND SUBTENDED BY A CHORD BEARING OF NORTH 23°59'27" WEST AND A CHORD DISTANCE OF 4.98 FEET TO THE POINT OF TANGENCY OF SAID CURVE; THENCE CONTINUING ALONG SAID NORTHERLY LINES THE FOLLOWING FOUR COURSES: NORTH 18°15'20" WEST, A DISTANCE OF 20.15 FEET; THENCE SOUTH 71°44'40" WEST, A DISTANCE OF 50.00 FEET TO A POINT ON A CURVE OF A CURVE CONCAVE TO THE NORTHWEST AND HAVING A RADIUS OF 25.00 FEET AND HAVING A CENTRAL ANGLE OF 90°04'06"; THENCE SOUTHWESTERLY ALONG SAID CURVE AN ARC DISTANCE OF 39.30 FEET AND BEING SUBTENDED BY A CHORD BEARING OF SOUTH 26°47'43" WEST AND A CHORD DISTANCE OF 35.38 FEET TO THE POINT OF TANGENCY OF SAID CURVE; THENCE SOUTH 71°49'46" WEST, A DISTANCE OF 114.96 FEET TO THE POINT OF BEGINNING. CONTAINING 26.73 ACRES, MORE OR LESS.



Together with

Phase 2A

A PORTION OF SECTIONS 13 AND 38, TOWNSHIP 12 SOUTH, RANGE 31 EAST, FLAGLER COUNTY, FLORIDA, AND BEING MORE PARTICULARLY DESCRIBED AS FOLLOWS: COMMENCE AT THE INTERSECTION OF THE EAST RIGHT OF WAY LINE OF JOHN ANDERSON HIGHWAY (COUNTY ROAD 201 AND A 100 FOOT RIGHT OF WAY) AND THE NORTH LINE OF SAID SECTION 38; THENCE SOUTH 18°10'14" EAST ALONG SAID EAST RIGHT OF WAY LINE, A DISTANCE OF 213.23 FEET; TO THE POINT OF BEGINNING, THENCE NORTH 71°49'46" EAST, DEPARTING FROM SAID RIGHT OF WAY LINE, A DISTANCE OF 225.00 FEET; THENCE SOUTH 18°10'14" EAST, A DISTANCE OF 87.31 FEET; THENCE NORTH 72°11'12" EAST, A DISTANCE OF 50.00 FEET TO A POINT ON A CURVE OF A CURVE CONCAVE TO THE NORTHEAST AND HAVING A RADIUS OF 25.00 FEET AND A CENTRAL ANGLE OF 10°56'26"; HENCE SOUTHEASTERLY ALONG SAID CURVE AN ARC DISTANCE OF 4.77 FEET AND SUBTENDED BY A CHORD BEARING OF SOUTH 23°37'58" EAST AND A CHORD DISTANCE OF 4.75 FEET TO A POINT ON A CURVE OF A CURVE CONCAVE TO SOUTH AND HAVING A RADIUS OF 495.00 FEET AND A CENTRAL ANGLE OF 14°32'52"; THENCE EASTERLY ALONG SAID CURVE AN ARC DISTANCE OF 125.35 FEET AND SUBTENDED BY A CHORD BEARING OF NORTH 78°18'07" EAST AND A CHORD DISTANCE OF 125.35 FEET TO A POINT ON SAID CURVE; THENCE NORTH 18°01'4" WEST, A DISTANCE OF 106.49 FEET; THENCE NORTH 71°49'46" EAST, A DISTANCE OF 80.00 FEET; THENCE SOUTH 18°10'14" EAST, A DISTANCE OF 50.30 FEET; THENCE SOUTH 02°02'07" WEST, A DISTANCE OF 77.22 FEET TO A POINT ON A CURVE OF A CURVE CONCAVE TO THE SOUTH AND HAVING A RADIUS OF 495.00 FEET AND A CENTRAL ANGLE OF 15°23'29"; THENCE EASTERLY ALONG SAID CURVE AN ARC DISTANCE OF 141.61 FEET AND SUBTENDED BY A CHORD BEARING OF SOUTH 78°46'17" EAST AND A CHORD DISTANCE OF 141.13 FEET TO A POINT ON SAID CURVE AND ALSO ON A CURVE OF A CURVE CONCAVE TO THE NORTHWEST AND HAVING A RADIUS OF 25.00 FEET AND A CENTRAL ANGLE OF 11°55'36"; THENCE NORTHEASTERLY ALONG SAID CURVE AN ARC DISTANCE OF 5.20 FEET AND SUBTENDED BY A CHORD BEARING OF NORTH 22°34'24" EAST AND A CHORD DISTANCE OF 5.19 FEET TO A POINT ON SAID CURVE; THENCE SOUTH 73°23'24" EAST, A DISTANCE OF 50.00 FEET TO A POINT ON A CURVE OF A CURVE CONCAVE TO THE EAST AND HAVING A RADIUS OF 25.00 FEET AND A CENTRAL ANGLE OF 11°32'13"; THENCE SOUTHERLY ALONG SAID CURVE AN ARC DISTANCE OF 5.03 FEET AND SUBTENDED BY A CHORD BEARING OF SOUTH 10°50'29" WEST AND A CHORD DISTANCE OF 5.03 FEET TO A POINT ON SAID CURVE; THENCE SOUTH 73°23'24" EAST, A DISTANCE OF 139.49 FEET; THENCE NORTH 16°36'36" EAST, A DISTANCE OF 16.72 FEET TO A POINT ON A CURVE OF A CURVE CONCAVE WESTERLY AND HAVING A RADIUS OF 365.00 FEET AND A CENTRAL ANGLE OF 34°46'50"; THENCE NORTHERLY ALONG SAID CURVE AN ARC DISTANCE OF 221.57 FEET AND SUBTENDED BY A CHORD BEARING OF NORTH 00°46'49" WEST AND A CHORD DISTANCE OF 218.18 FEET TO THE POINT OF TANGENCY OF SAID CURVE; THENCE NORTH 18°10'14" WEST, A DISTANCE OF 24.44 FEET; THENCE SOUTH 71°49'46" WEST, A DISTANCE OF 140.00 FEET; THENCE NORTH 18°10'14" WEST, A DISTANCE OF 20.00 FEET; THENCE NORTH 71°49'46" EAST, A DISTANCE OF 140.00 FEET; THENCE NORTH 18°10'14" WEST, A DISTANCE OF 935.73 FEET; THENCE NORTH 01°32'26" WEST, A DISTANCE OF 384.95 FEET; THENCE SOUTH 88°27'34" WEST, A DISTANCE OF 140.00 FEET; THENCE NORTH 01°32'26" WEST, A DISTANCE OF 20.00 FEET; THENCE NORTH 88°27'34" EAST, A DISTANCE OF 140.00 FEET; THENCE NORTH 01°32'26" WEST, A DISTANCE OF 48.29 FEET; THENCE NORTH 18°10'14" WEST, A DISTANCE OF 809.39 FEET; THENCE NORTH 71°49'46" EAST, A DISTANCE OF 218.41 FEET; THENCE SOUTH 18°10'14" EAST, A DISTANCE OF 40.00 FEET; THENCE NORTH 71°49'46" EAST, A DISTANCE OF 557.17 FEET TO THE POINT OF CURVE OF A CURVE CONCAVE TO THE SOUTHWEST AND HAVING A RADIUS OF 5.00 FEET AND A CENTRAL ANGLE OF 90°00'00"; THENCE SOUTHEASTERLY ALONG SAID CURVE AN ARC DISTANCE OF 7.07 FEET AND SUBTENDED BY A CHORD BEARING OF SOUTH 63°01'4" EAST AND A CHORD DISTANCE OF 7.07 FEET TO A POINT ON SAID CURVE; THENCE NORTH 71°49'46" EAST, A DISTANCE OF 70.00 FEET TO A POINT ON A CURVE OF A CURVE CONCAVE TO THE SOUTHEAST AND HAVING A RADIUS OF 39.27 FEET AND A CENTRAL ANGLE OF 90°00'00"; THENCE NORTHEASTERLY ALONG SAID CURVE AN ARC DISTANCE OF 39.27 FEET AND SUBTENDED BY A CHORD BEARING OF NORTH 25°49'46" EAST AND A CHORD DISTANCE OF 35.36 FEET TO THE POINT OF TANGENCY OF SAID CURVE; THENCE NORTH 71°49'46" EAST, A DISTANCE OF 134.59 FEET; THENCE SOUTH 18°10'14" EAST, A DISTANCE OF 50.00 FEET; THENCE NORTH 71°49'46" EAST, A DISTANCE OF 50.00 FEET; THENCE NORTH 18°10'14" WEST, A DISTANCE OF 50.00 FEET; THENCE NORTH 71°49'46" EAST, A DISTANCE OF 149.59 FEET TO THE POINT OF CURVE OF A CURVE CONCAVE TO THE SOUTH WEST AND HAVING A RADIUS OF 25.00 FEET AND A CENTRAL ANGLE OF 90°00'00"; THENCE SOUTHEASTERLY ALONG SAID CURVE AN ARC DISTANCE OF 39.27 FEET AND SUBTENDED BY A CHORD BEARING OF SOUTH 83°10'3" EAST AND A CHORD DISTANCE OF 35.36 FEET TO THE POINT OF TANGENCY OF SAID CURVE; THENCE SOUTH 18°10'14" EAST, A DISTANCE OF 3.02 FEET; THENCE NORTH 71°49'46" EAST, A DISTANCE OF 334.12 FEET TO A POINT ON THE WEST RIGHT OF WAY LINE OF FLORIDA INTRACASTAL WATERWAY; THENCE ALONG SAID WEST RIGHT OF WAY LINE THE FOLLOWING THREE COURSES: SOUTH 13°58'25" EAST, A DISTANCE OF 799.39 FEET; THENCE SOUTH 21°17'55" EAST, A DISTANCE OF 1265.37 FEET; THENCE SOUTH 03°54'39" WEST, A DISTANCE OF 90.51 FEET; THENCE SOUTH 69°00'58" WEST, DEPARTING FROM SAID WEST RIGHT OF WAY LINE, A DISTANCE OF 250.79 FEET TO THE POINT OF CURVE OF A CURVE CONCAVE TO THE NORTHEAST AND HAVING A RADIUS OF 65.00 FEET AND A CENTRAL ANGLE OF 140°24'30"; THENCE NORTHWESTERLY ALONG SAID CURVE AN ARC DISTANCE OF 159.29 FEET AND SUBTENDED BY A CHORD BEARING OF NORTH 41°16'28" WEST AND A CHORD DISTANCE OF 122.32 FEET TO A POINT ON SAID CURVE; THENCE SOUTH 69°00'06" WEST, A DISTANCE OF 85.08 FEET; THENCE NORTH 20°54'52" WEST, A DISTANCE OF 180.00 FEET; THENCE SOUTH 69°00'06" WEST, A DISTANCE OF 503.11 FEET TO THE POINT OF CURVE OF A CURVE CONCAVE TO THE SOUTHEAST AND HAVING A RADIUS OF 5.00 FEET AND A CENTRAL ANGLE OF 90°00'00"; THENCE SOUTHWESTERLY ALONG SAID CURVE AN ARC DISTANCE OF 7.85 FEET AND SUBTENDED BY A CHORD BEARING OF SOUTH 24°00'06" WEST AND A CHORD DISTANCE OF 7.87 FEET TO THE POINT OF TANGENCY OF SAID CURVE; THENCE SOUTH 20°58'54" EAST, A DISTANCE OF 822.65 FEET TO A POINT ON A CURVE OF A CURVE CONCAVE TO THE NORTHEAST AND HAVING A RADIUS OF 25.00 FEET AND A CENTRAL ANGLE OF 11°10'11"; THENCE SOUTHEASTERLY ALONG SAID CURVE AN ARC DISTANCE OF 4.87 FEET AND SUBTENDED BY A CHORD BEARING OF NORTH 74°57'14" EAST AND A CHORD DISTANCE OF 4.87 FEET TO A POINT ON SAID CURVE; THENCE SOUTH 21°21'58" EAST, A DISTANCE OF 50.00 FEET TO A POINT ON A CURVE OF A CURVE CONCAVE TO THE SOUTHEAST AND HAVING A RADIUS OF 25.00 FEET AND A CENTRAL ANGLE OF 90°22'02"; THENCE SOUTHWESTERLY ALONG SAID CURVE AN ARC DISTANCE OF 39.43 FEET AND SUBTENDED BY A CHORD BEARING OF SOUTH 24°11'07" WEST AND A CHORD DISTANCE OF 35.47 FEET TO A POINT ON SAID CURVE; THENCE SOUTH 69°44'0" WEST, A DISTANCE OF 50.00 FEET TO A POINT ON A CURVE OF A CURVE TO THE SOUTHWEST AND HAVING A RADIUS OF 25.00 FEET AND A CENTRAL ANGLE OF 11°01'1"; THENCE NORTHWESTERLY ALONG SAID CURVE AN ARC DISTANCE OF 4.87 FEET AND SUBTENDED BY A CHORD BEARING OF NORTH 26°34'59" WEST AND A CHORD DISTANCE OF 4.87 FEET TO A POINT ON SAID CURVE; THENCE SOUTH 69°22'08" WEST, A DISTANCE OF 129.58 FEET; THENCE SOUTH 20°51'44" EAST, A DISTANCE OF 115.00 FEET; THENCE SOUTH 69°22'08" WEST, A DISTANCE OF 232.49 FEET; THENCE SOUTH 24°30'13" EAST, A DISTANCE OF 127.26 FEET; THENCE SOUTH 10°41'45" WEST, A DISTANCE OF 133.22 FEET; THENCE SOUTH 43°42'12" WEST, A DISTANCE OF 202.16 FEET; THENCE NORTH 32°58'38" WEST, A DISTANCE OF 357.54; THENCE NORTH 12°24'49" WEST, A DISTANCE OF 43.38 FEET; THENCE SOUTH 71°49'46" WEST, A DISTANCE OF 68.04 FEET; THENCE NORTH 18°10'14" WEST, A DISTANCE OF 152.62 FEET; THENCE NORTH 16°36'36" EAST, A DISTANCE OF 82.23 FEET; THENCE NORTH 73°23'24" WEST, A DISTANCE OF 139.49 FEET TO A POINT ON A CURVE OF A CURVE CONCAVE TO THE SOUTHEAST AND HAVING A RADIUS OF 25.00 FEET AND A CENTRAL ANGLE OF 11°32'13"; THENCE SOUTHEASTERLY ALONG SAID CURVE AN ARC DISTANCE OF 5.03 FEET AND SUBTENDED BY A CHORD BEARING OF SOUTH 22°22'42" WEST AND A CHORD DISTANCE OF 5.03 FEET TO A POINT ON SAID CURVE; THENCE NORTH 73°23'24" WEST, A DISTANCE OF 50.00 FEET TO A POINT ON A CURVE OF A CURVE CONCAVE TO THE WEST AND HAVING A RADIUS OF 25.00 FEET AND A CENTRAL ANGLE OF 11°32'13"; THENCE NORTHERLY ALONG SAID CURVE AN ARC DISTANCE OF 5.03 FEET AND SUBTENDED BY A CHORD BEARING OF NORTH 0°50'29" EAST AND A CHORD DISTANCE OF 5.03 FEET TO A POINT ON SAID CURVE; THENCE NORTH 73°23'24" WEST, A DISTANCE OF 139.49 FEET; THENCE SOUTH 16°36'36" WEST, A DISTANCE OF 62.75 FEET; THENCE SOUTH 71°49'46" WEST, A DISTANCE OF 190.07 FEET; THENCE NORTH 18°10'14" WEST, A DISTANCE OF 150.73 FEET TO A POINT ON A CURVE CONCAVE TO THE SOUTH AND HAVING A RADIUS OF 355.00 FEET AND A CENTRAL ANGLE OF 04°50'36"; THENCE WESTERLY ALONG SAID CURVE AN ARC DISTANCE OF 30.01 FEET AND SUBTENDED BY A CHORD BEARING OF SOUTH 74°15'04" WEST AND A CHORD DISTANCE OF 30.00 FEET TO THE POINT OF TANGENCY OF SAID CURVE; THENCE SOUTH 71°49'46" WEST, A DISTANCE OF 84.52 FEET TO A POINT ON A CURVE OF A CURVE CONCAVE TO THE EAST AND HAVING A RADIUS OF 25.00 FEET AND A CENTRAL ANGLE OF 11°32'05" EAST; THENCE SOUTHERLY ALONG SAID CURVE AN ARC DISTANCE OF 5.02 FEET AND SUBTENDED BY A CHORD BEARING OF SOUTH 12°24'05" EAST AND A CHORD DISTANCE OF 5.02 FEET TO A POINT ON SAID CURVE; THENCE SOUTH 71°49'46" WEST, A DISTANCE OF 50.00 FEET; THENCE SOUTH 18°10'14" EAST, A DISTANCE OF 67.00 FEET; THENCE SOUTH 71°49'46" WEST, A DISTANCE OF 225.00 FEET TO THE INTERSECTION WITH THE AFOREMENTIONED EAST RIGHT OF WAY LINE OF JOHN ANDERSON HIGHWAY; THENCE NORTH 18°10'14" WEST, ALONG SAID RIGHT OF WAY LINE, A DISTANCE OF 304.31 FEET; TO THE POINT OF BEGINNING.

CONTAINING 97.66 ACRES, MORE OR LESS

Together with

Phase 2B

A PORTION OF SECTIONS 13 AND 38, TOWNSHIP 12 SOUTH, RANGE 31 EAST, FLAGLER COUNTY, FLORIDA, AND BEING MORE PARTICULARLY DESCRIBED AS FOLLOWS: COMMENCE AT THE INTERSECTION OF THE EAST RIGHT OF WAY LINE OF JOHN ANDERSON HIGHWAY (STATE ROAD 201 AND A 100 FOOT RIGHT OF WAY) AND THE NORTH LINE OF SAID SECTION 38; THENCE SOUTH  $18^{\circ}10'14''$  EAST ALONG SAID EAST RIGHT OF WAY LINE, A DISTANCE OF 331.23 FEET; THENCE NORTH  $71^{\circ}49'46''$  EAST, DEPARTING FROM SAID RIGHT OF WAY LINE, A DISTANCE OF 400.00 FEET TO THE POINT OF BEGINNING; THENCE CONTINUE NORTH  $71^{\circ}49'46''$  EAST, A DISTANCE OF 370.00 FEET; THENCE NORTH  $18^{\circ}10'14''$  WEST, A DISTANCE OF 325.00 FEET; THENCE NORTH  $71^{\circ}49'46''$  EAST, A DISTANCE OF 50.00 FEET; THENCE NORTH  $18^{\circ}10'14''$  WEST, A DISTANCE OF 20.01 FEET TO THE POINT OF CURVE OF A CURVE CONCAVE TO THE EAST AND HAVING A RADIUS OF 25.00 FEET AND A CENTRAL ANGLE OF  $11^{\circ}32'14''$ ; THENCE NORTHERLY ALONG SAID CURVE AN ARC DISTANCE OF 5.03 FEET AND SUBTENDED BY A CHORD BEARING OF NORTH  $12^{\circ}24'08''$  WEST AND A CHORD DISTANCE OF 5.03 FEET TO A POINT ON SAID CURVE; THENCE NORTH  $71^{\circ}49'46''$  EAST, A DISTANCE OF 119.50 FEET; THENCE SOUTH  $18^{\circ}10'14''$  EAST, A DISTANCE OF 809.39 FEET; THENCE SOUTH  $01^{\circ}32'26''$  WEST, A DISTANCE OF 49.29 FEET; THENCE SOUTH  $88^{\circ}27'34''$  WEST, A DISTANCE OF 140.00 FEET; THENCE SOUTH  $01^{\circ}32'26''$  EAST, A DISTANCE OF 20.00 FEET; THENCE NORTH  $88^{\circ}27'34''$  EAST, A DISTANCE 140.00 FEET; THENCE SOUTH  $01^{\circ}32'26''$  EAST, A DISTANCE OF 384.95 FEET; SOUTH  $18^{\circ}10'14''$  EAST, A DISTANCE OF 935.73 FEET; THENCE SOUTH  $71^{\circ}49'46''$  WEST, A DISTANCE OF 140.00 FEET; THENCE SOUTH  $18^{\circ}10'14''$  EAST, A DISTANCE OF 20.00 FEET; THENCE NORTH  $71^{\circ}49'46''$  EAST, A DISTANCE OF 140.00 FEET; THENCE SOUTH  $18^{\circ}10'14''$  EAST, A DISTANCE OF 24.44 FEET TO THE POINT OF CURVE OF A CURVE CONCAVE TO THE WEST AND HAVING A RADIUS OF 365.00 FEET AND A CENTRAL ANGLE OF  $34^{\circ}46'50''$ ; THENCE SOUTHERLY ALONG SAID CURVE AN ARC DISTANCE OF 221.57 FEET AND SUBTENDED BY CHORD BEARING OF SOUTH  $00^{\circ}46'49''$  EAST AND A CHORD DISTANCE OF 218.18 FEET TO THE POINT OF TANGENT OF SAID CURVE; THENCE SOUTH  $16^{\circ}36'36''$  WEST, A DISTANCE OF 18.72 FEET; THENCE NORTH  $73^{\circ}23'24''$  WEST, A DISTANCE OF 139.49 FEET TO A POINT ON A CURVE OF A CURVE CONCAVE TO THE EAST AND HAVING A RADIUS OF 25.00 FEET AND A CENTRAL ANGLE OF  $11^{\circ}32'13''$ ; THENCE NORTHERLY ALONG SAID CURVE AN ARC DISTANCE OF 5.03 FEET AND SUBTENDED BY A CHORD BEARING OF NORTH  $10^{\circ}50'29''$  EAST AND A CHORD DISTANCE OF 5.03 FEET TO A POINT ON SAID CURVE; THENCE NORTH  $73^{\circ}28'41''$  WEST, A DISTANCE OF 50.00 FEET TO A POINT ON A CURVE OF A CURVE CONCAVE TO THE NORTHWEST AND HAVING A RADIUS OF 25.00 FEET AND A CENTRAL ANGLE OF  $12^{\circ}16'44''$ ; THENCE SOUTHWESTERLY ALONG SAID CURVE AN ARC DISTANCE OF 5.36 FEET AND SUBTENDED BY A CHORD BEARING OF SOUTH  $22^{\circ}44'58''$  WEST AND A CHORD DISTANCE OF 5.35 FEET TO A POINT ON A CURVE OF A CURVE CONCAVE TO THE SOUTH AND HAVING A RADIUS OF 495.00 AND A CENTRAL ANGLE OF  $16^{\circ}23'29''$ ; THENCE WESTERLY ALONG SAID CURVE AN ARC DISTANCE OF 141.61 FEET AND SUBTENDED BY A CHORD BEARING OF NORTH  $79^{\circ}46'17''$  WEST AND A CHORD DISTANCE OF 141.13 FEET TO A POINT ON SAID CURVE; THENCE NORTH  $02^{\circ}02'07''$  EAST, A DISTANCE OF 77.22 FEET; THENCE NORTH  $18^{\circ}10'14''$  WEST, A



DISTANCE OF 50.30 FEET; THENCE SOUTH 71°49'46" WEST, A DISTANCE OF 80.00 FEET; THENCE NORTH 18°10'14" WEST, A DISTANCE OF 1800.00 FEET TO THE POINT OF BEGINNING.  
CONTAINING 21.82 ACRES, MORE OR LESS.

Together with

Phase 2C

A PORTION OF SECTION 38, TOWNSHIP 12 SOUTH, RANGE 31 EAST, FLAGLER COUNTY, FLORIDA, AND BEING MORE PARTICULARLY DESCRIBED AS FOLLOWS: COMMENCE AT THE INTERSECTION OF THE EAST RIGHT OF WAY LINE OF JOHN ANDERSON HIGHWAY (STATE ROAD 201 AND A 100 FOOT RIGHT OF WAY) AND THE NORTH LINE OF SAID SECTION 38; THENCE SOUTH 18°10'14" EAST ALONG SAID EAST RIGHT OF WAY LINE, A DISTANCE OF 331.23 FEET TO THE POINT OF BEGINNING; THENCE NORTH 71°49'46" EAST, DEPARTING FROM SAID RIGHT OF WAY LINE, A DISTANCE OF 400.00 FEET; THENCE SOUTH 18°10'14" EAST, A DISTANCE OF 1906.48 FEET TO A POINT ON A CURVE OF A CURVE CONCAVE TO THE SOUTH AND HAVING A RADIUS OF 495.00 FEET AND A CENTRAL ANGLE OF 14°32'52"; THENCE WESTERLY ALONG SAID CURVE AN ARC DISTANCE OF 125.68 FEET AND SUBTENDED BY A CHORD BEARING OF SOUTH 78°18'07" WEST AND A CHORD DISTANCE OF 125.35 FEET TO A POINT OF A CURVE OF A CURVE CONCAVE TO THE NORTHEAST AND HAVING A RADIUS OF 25.00 FEET AND A CENTRAL ANGLE OF 10°55'26"; THENCE NORTHWESTERLY ALONG SAID CURVE AN ARC DISTANCE OF 4.77 FEET AND SUBTENDED BY A CHORD BEARING OF NORTH 23°37'58" WEST AND A CHORD DISTANCE OF 4.76 FEET; THENCE; THENCE SOUTH 72°11'12" WEST, A DISTANCE OF 50.00 FEET; THENCE NORTH 18°10'14' WEST, A DISTANCE OF 87.31 FEET; THENCE SOUTH 71°49'46" WEST, A DISTANCE OF 225.00 FEET TO THE INTERSECTION WITH THE AFOREMENTIONED EAST RIGHT OF WAY LINE OF JOHN ANDERSON HIGHWAY; THENCE NORTH 18°10'14" WEST, ALONG SAID RIGHT OF WAY LINE, A DISTANCE OF 1800.00 FEET TO THE POINT OF BEGINNING.  
CONTAINING 16.91 ACRES, MORE OR LESS.

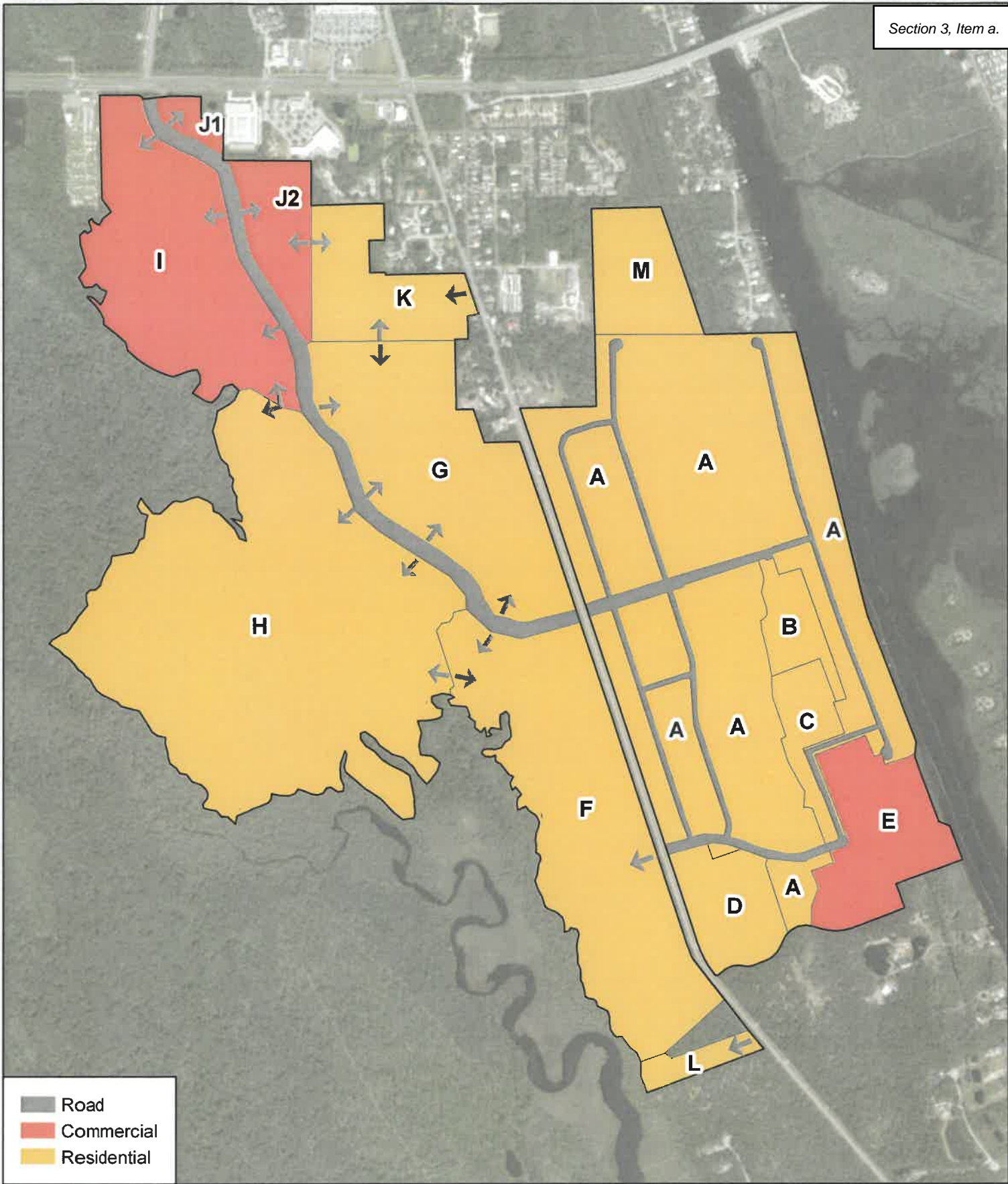
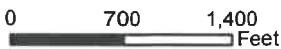
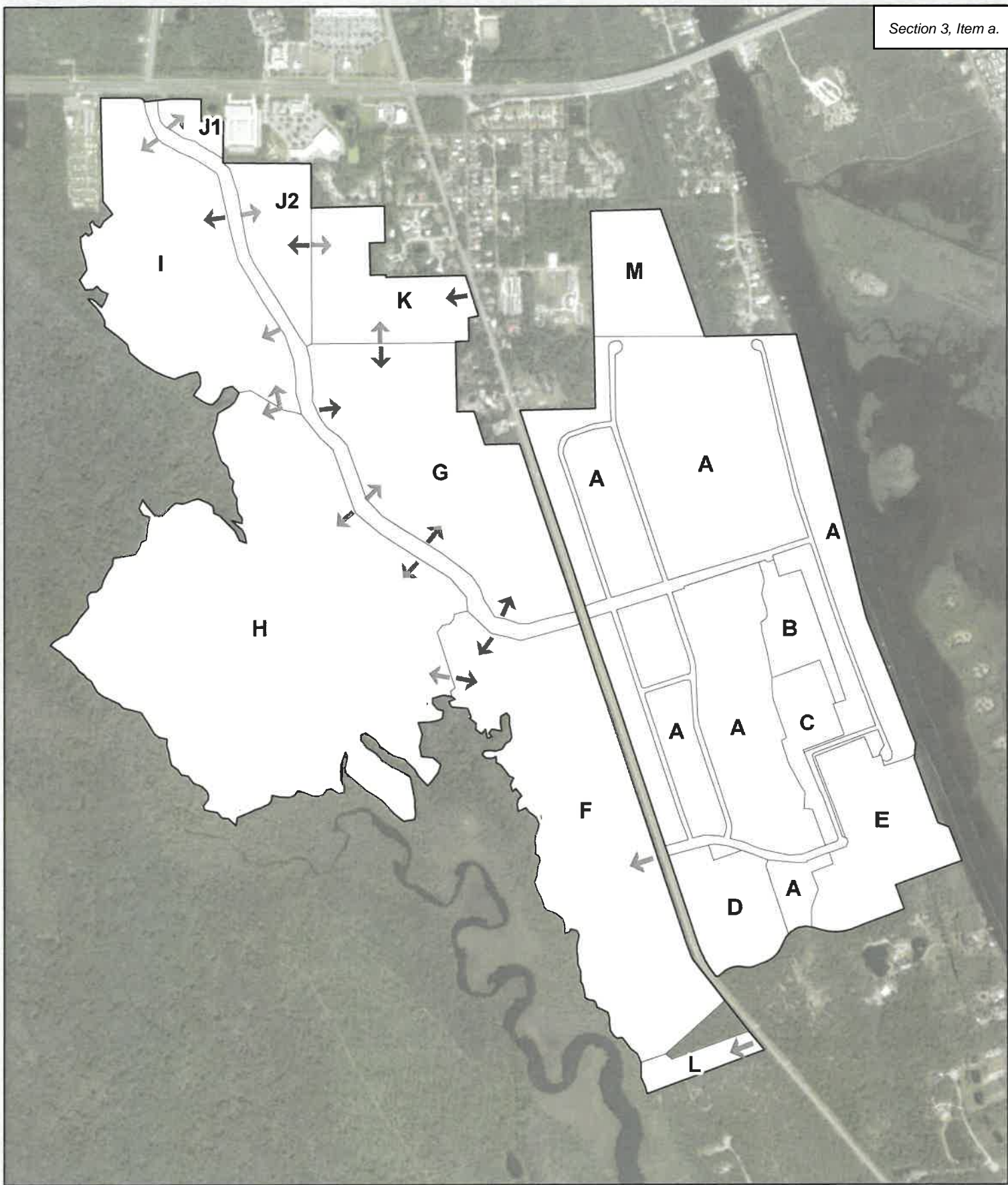

Exhibit "C"  
MPD Master Plan  
Veranda Bay  
Flagler County, Florida

Date: 6-20-24





Date: 6-20-24

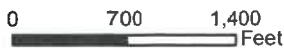
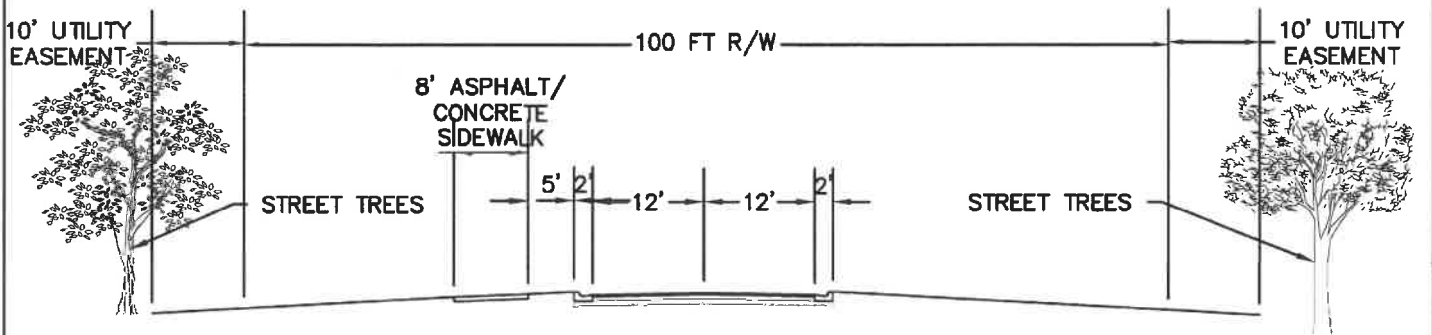

Exhibit "D"  
Tract Map  
Veranda Bay  
Flagler County, Florida





## VERANDA BAY SPINE ROAD SECTION

PROFESSIONAL ENGINEERS \* LANDSCAPE ARCHITECTS  
1729 RIDGEWOOD AVENUE HOLLY HILL, FLORIDA 32117  
(386) 677-6891 FAX (386) 677-2114 E-MAIL: info@parkermynchenberg.com  
CERTIFICATE OF AUTHORIZATION NUMBER 00003910

**EXHIBIT E**





EXHIBIT "F"

File No.	
Drawn By	SLB
Date	6/1/2024

VERANDA BAY – MPD MASTER DEVELOPMENT PLAN FLAGLER BEACH, FLAGLER COUNTY, FLORIDA
MPD – MASTER DRAINAGE PLAN

**PARKER MYNCHENBERG & ASSOCIATES, INC.**  
 PROFESSIONAL ENGINEERS • LANDSCAPE ARCHITECTS  
 1729 RIDGEWOOD AVENUE • HOLLY HILL, FLORIDA 32117  
 (386) 677-8891 FAX (386) 877-2114 E-MAIL: info@parkermynchberg.com  
 PARKER MYNCHENBERG & ASSOCIATES, INC. A FLORIDA CORPORATION  
 STEVE BISHOP, P.E. (00008314, FLA000101)  
 JOHN A. LITTON, P.E.  
 CERTIFICATE OF AUTHORIZATION NUMBER 00003910

NO.	DATE	DESCRIPTION	BY

Veranda Bay - Land Use Exchange Table

Land Use Type	Proposed Quantity	Units	Net External PM Peak	
			Trips	Trip Rate
Single-Family Detached Housing	1,053	DUs	876	0.832
Recreational Community Center/Clubhouse and Amenity Center	6	KSF	14	2.258
Multifamily Housing (Low-Rise)	1,682	DUs	675	0.401
Yacht Club - Commercial (Strip Retail Plaza (<40k))	10	KSF	52	5.2
Marina	150	Berths	28	0.187
Retail/Commercial/Office	436	KSF	1,156	2.65
Hotel	250	Rooms	135	0.54

Source: Table 08, Trip Generation - PM Peak

	Convert To						
	Single Family Residential	Recreational Community Center	Multi-Family Residential	Yacht Club Commercial	Marina	Retail/Commercial Office	Hotel
Convert From							
Single-Family Detached Housing	1.000	0.368	2.075	0.160	4.449	0.314	1.541
Recreational Community Center/Clubhouse and Amenity Center	2.714	1.000	5.631	0.434	12.075	0.852	4.181
Multifamily Housing (Low-Rise)	0.482	0.178	1.000	0.077	2.144	0.151	0.743
Yacht Club - Commercial (Strip Retail Plaza (<40k))	6.250	2.303	12.968	1.000	27.807	1.962	9.630
Marina	0.225	0.083	0.466	0.036	1.000	0.071	0.346
Retail/Commercial/Office	3.185	1.174	6.608	0.510	14.171	1.000	4.907
Hotel	0.649	0.239	1.347	0.104	2.888	0.204	1.000

**Example:**

To convert 50 Single Family Residential Dwelling Units to Shopping/Retail/Office, multiply 50 \* 0.314 =

15,698.00 SF

To convert 10,000 SF Shopping/Retail/Office to Single Family Detached Residential, multiply 10,000/1,000 \* 3.185

32.00 Units