



**Flagler County Tourist Development Council**

1769 East Moody Boulevard, Suite 311  
Bunnell, Florida 32110  
(386) 313-4013

**Fund 109 Capital Improvements**

www.palmcoastandtheflaglerbeaches.com **Request for Public Tourism Infrastructure Funding**

**Organization Information**

Organization Name TOWN OF BEVERLY BEACH, FLORIDA

Contact Person COMMISSIONER LARRY MATHIES

Email Address larrymathies@gmail.com

Mailing Address 2735 N OCEANSHORE BLVD., BEVERLY BEACH, FL 32136

Phone 386-439-6888

Fax 386-439-3202

**For Public Tourism Infrastructure Grants to a Local (City or County) Government Organization:**

- \* Maximum of \$150,000 per project;
- \* No more than two public tourism infrastructure projects will be funded to an organization at one time;
- \* Maximum of two projects every five years; and
- \* Public tourism infrastructure projects will be evaluated based on multiple criteria.

**Project Description**

Project Name: BEACH WALKOVER RENOVATION & RECONSTRUCTION

Est. Project Start Date 11/01/16

Est. Project Completion Date 01/31/17

**Brief Description of Project**

The project is the restoration of two primary dune walkovers located directly on SF A1A near the Si Como No Motel and Oceanside Condominiums. Both walkovers are frequented by winter Floridians and tourists on a daily basis. The project consists of removing all aged, rotted, or otherwise unsuitable materials and replacing them with marine grade materials and hardware, including composite weatherproof materials like those used in our last renovation. Work will be performed by licensed and insured contractors with relevant experience.

**Please attach a typed sheet and answer the following questions: (No Longer than one page)**

- 1 What is the intended use of funds requested for Project?
- 2 How will the project enhance Flagler County tourism?
- 3 What are the operation aspects of the project (i.e. hours of operation)?
- 4 How will this project promote or enhance overnight stays in Flagler County?

1. The intended use of the funds is to completely renovate two of the Towns pedestrian dune walkovers, one of which is closed for public safety and the other which is in bad need of attention.
2. Renovation of the walkovers will provide safe access to the Beach from A1A for all including overnight and day visitors.
3. The walkovers are provided at no charge and are accessible 24 hours a day, seven days a week.
4. The two walkovers are directly across A1A from the Si Como No Motel and two large Condominiums which provide short term rentals.

Larry Mathies

Commissioner, Beverly Beach

**Funding**

Amount of TDC funding Requested \$ 32,000.00

What is the total budget amount for the Project? \$ 32,000.00

**\*A line item budget must be submitted together with this application showing all funding sources and expenditures for the project**

If the entire request cannot be funded, can the project be phased for less funding?  Yes  No

If yes please indicate minimum amount necessary for next phase \$ \_\_\_\_\_

If the project cannot be phased, please explain.

To perform the project properly, all the decking must be removed to inspect the structural members that would render the walkovers unusable to visitors who normally expect them to be open 24/7.

List past TDC funding in last five (5) years:

Year	Project	Requested Amt	Award Amt	Spent Amt
2014	Dune Walkover #2	15,000.00	15,000.00	19,500

Provide all additional outside contributors, sponsors, and sources of funding for this project. (If not applicable, please explain.)

At this time the only other source of outside funding is a \$1,000.00 matching grant from Florida Municipal Insurance Trust. That funding will be used for interim repairs to make the walkover safe enough for public use until the full refurbishment can take place.

What funding and in kind service is your organization providing?

Interim financing from start to finish pursuant to reimbursement of costs by this grant.

What additional sources of funding has your organization sought?

Only the above-referenced matching grant.

How will TDC funding help this project?

The Town of Beverly Beach has very limited financial resources to spend for this project. Our available resources are primarily segregated to address the Town's essential and required operational functions.

I am the Authorized Agent of the organization requesting TDC funds. I have reviewed this Application for Funds from the Flagler County Tourist Development Council and concur with the information submitted herein. To the best of my knowledge and belief, the information contained in this Application and its attachments is accurate and complete. If funds are awarded, I agree to follow all policies of the Flagler County Tourist Development Council relative to this grant. I also understand that funds will be provided on a reimbursement basis as a lump sum payment upon project completion and upon meeting of all grant award requirements. I understand that I can only apply for two grants every five years.

Larry Mathies  
*Authorized Agent Signature*

4/5/2016  
*Date*

Print Name: LARRY MATHIES

Title: COMMISSIONER

# PRESENTATION TO THE FLAGLER COUNTY TOURIST DEVELOPMENT COUNCIL

The Town of Beverly Beach maintains four *public access beach walkovers*, which guide visitors and residents to the beach from SR A1A via acceptable, safe routes. The walkovers also provide protection for the dunes and vegetation from harmful activities. These structures are subject to the ravages of wind, salt water, sun, and tides, which dictate periodic repair or replacement.

The Town requested – and was granted – a TDC Grant in 2014 for \$15,000.00 and total renovated one of the major walkovers at a final cost of \$20,035.00, the difference of which was borne by the Town. The addition of ADA accessible handrails generated the majority of the cost overrun. See attached photo exhibits 1 and 2.

There are two more public access walkovers south of the renovated structure that also require the same degree of attention. See attached photo exhibits 3 and 4. One is currently closed due to removal of the steps because of its poor condition. While the Town recognizes the tourism value of these structures, the cost of renovation is more than the Town's "shoestring" budget can cope with.

Somewhat smaller in scope, the estimated cost of the work required for the two walkovers is \$32,000.00 (including the ADA handrails). The Town of Beverly Beach hereby requests a grant from the Flagler County Tourist Development Council in the amount of \$32,000.00 for renovation of its walkovers #3 and #4.

Respectfully,  
The Town of Beverly Beach, Florida



**PHOTO EXHIBIT #1**  
**Beverly Beach #2 Walkover BEFORE Renovation**



**PHOTO EXHIBIT #2**  
**Beverly Beach #2 Walkover AFTER Renovation**





**PHOTO EXHIBIT #3**  
**Beverly Beach #3 Walkover**

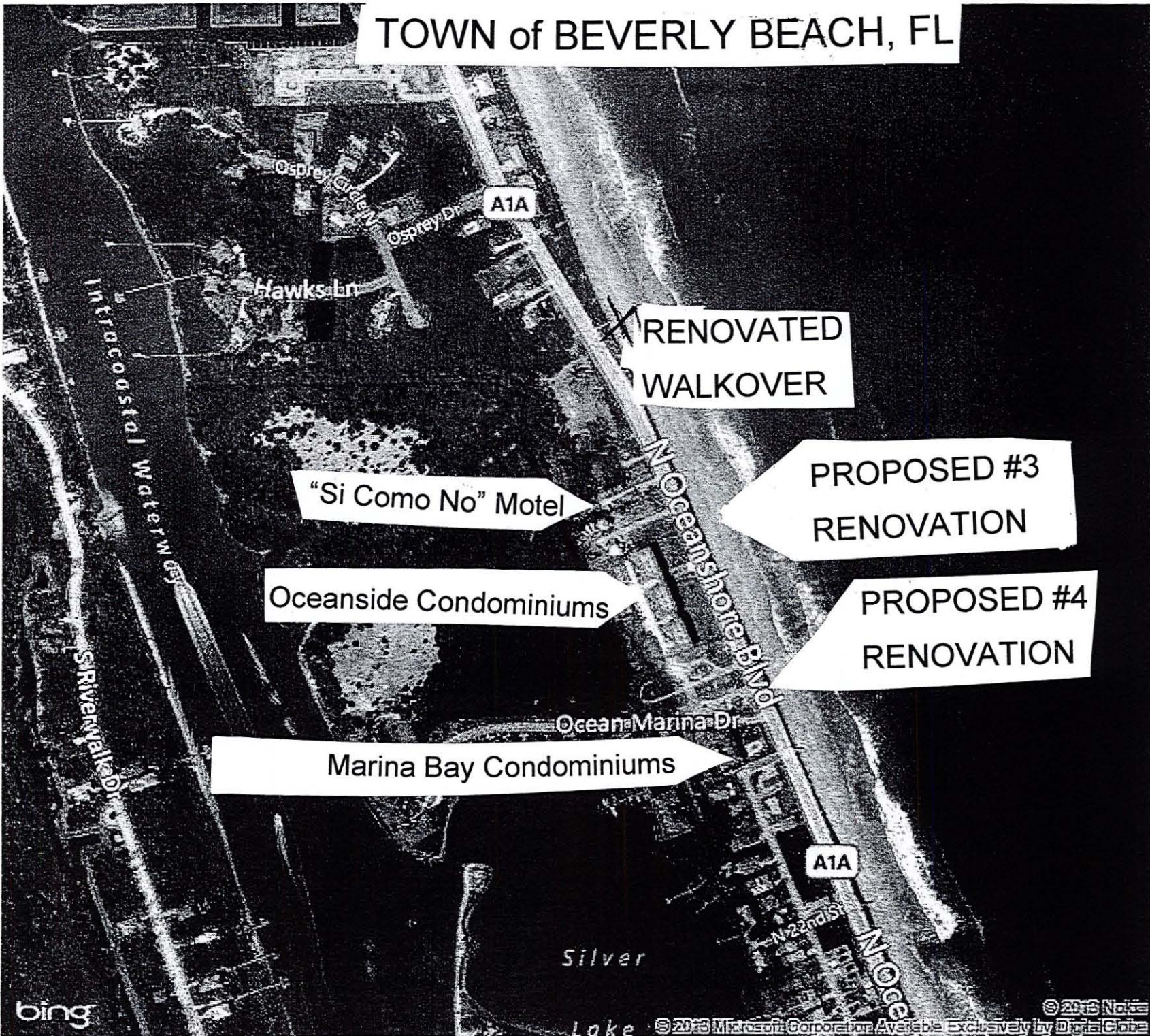

**PHOTO EXHIBIT #4**  
**Beverly Beach #4 Walkover (Closed)**





# TOWN of BEVERLY BEACH, FL



RENOVATED  
WALKOVER

"Si Como No" Motel

PROPOSED #3  
RENOVATION

Oceanside Condominiums

PROPOSED #4  
RENOVATION

Marina Bay Condominiums



# TOWN of BEVERLY BEACH, FLORIDA

## PLAN VIEW WALKOVER #3

State Route A1A

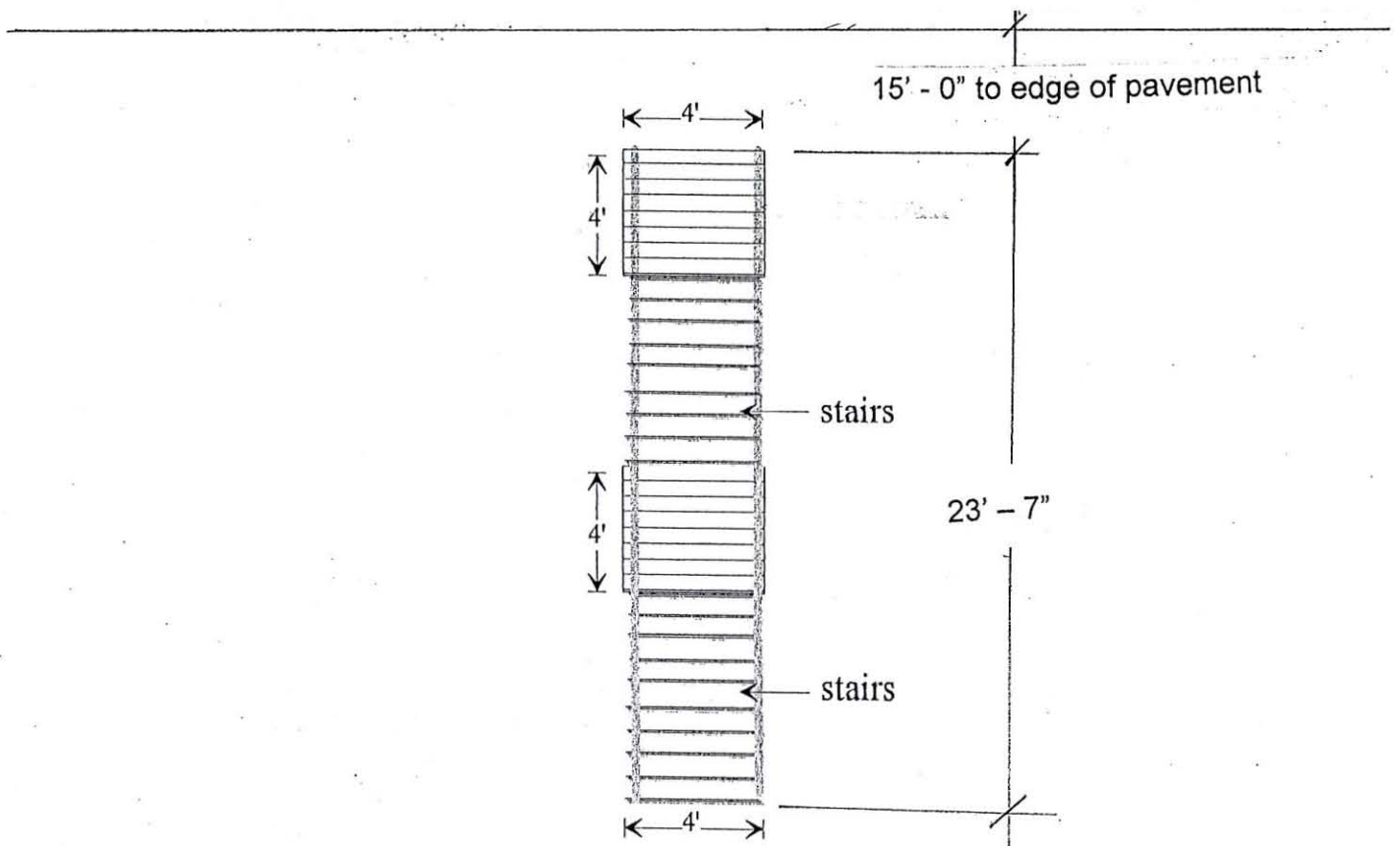

# TOWN of BEVERLY BEACH, FLORIDA

## PLAN VIEW WALKOVER #4

State Route A1A

